

Handling modules HSP



Handling modules HSP

Key features at a glance



Field of application

The handling module is a new generation of function modules for the automatic transfer, feed and removal of small parts in extremely confined spaces.

This is achieved by means of a guided vertical and horizontal motion sequence. A backlash-free cross-guide

with recirculating ball bearing elements ensures high precision and good rigidity. The combination of a semi-rotary drive and a slotted guide system produces a compact unit for a complete pick and place cycle.

Special features

- Compact design
- Extremely short cycle times
- Low cost
- Simple commissioning
- For working loads up to 1.6 kg
- Stroke adjustment along Y- and Z-axes
- Wait positions possible
- No planning costs

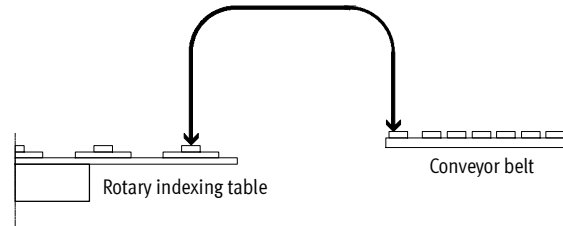

Three drive variants are available

	Pneumatic: HSP-...-AP, with swivel module DSM	Electric: HSP-...-AE, with servo motor unit MTR-DCI-...-HM	Without drive: HSP-...-AS, with drive shaft
Advantages			
	<ul style="list-style-type: none"> • Fast • Cost-effective • Ready to install • No system planning required • Simple commissioning 	<ul style="list-style-type: none"> • Freely positionable • Freely selectable speed • Smooth motion sequence • Ready to install • No system planning required • Simple commissioning using teach-in procedure 	<ul style="list-style-type: none"> • Compact • Universal compatibility • Variable drive interface • On request: Drive options in combination with servo motors MTR-AC
Technical data			
Stroke	Y [mm]	52 ... 170	
	Z [mm]	20 ... 70	
Min. cycle time	[s]	0.6 ... 1.0	0.8 ... 1.2
Working load	[g]	0 ... 1600	
Repetition accuracy at end positions	[mm]	±0.02	
Wait positions		Max. 2	Any
Function of wait position		Pulling with return cylinder	Freely approachable
Repetition accuracy at wait positions	[mm]	< 1	< 2
Data sheet		→ 8	→ 18
			→ 32

Handling modules HSP

Typical applications

HSP...-AP, pneumatic

Linear transfer

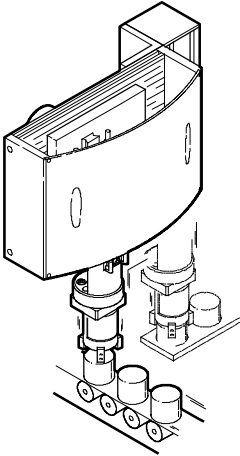

- Fast feed and removal, e.g. for linear transfer or rotary indexing table

Belt-type part positioning

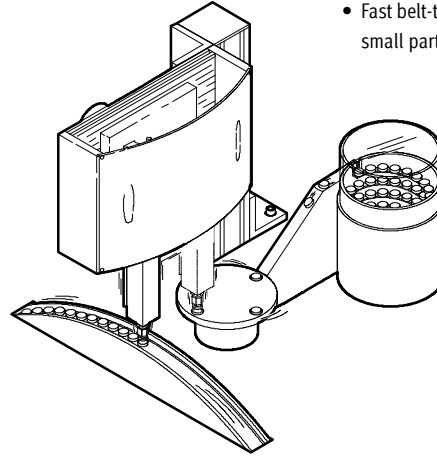

- Fast belt-type part positioning of small parts

HSP...-AE, electric

Rotary indexing table

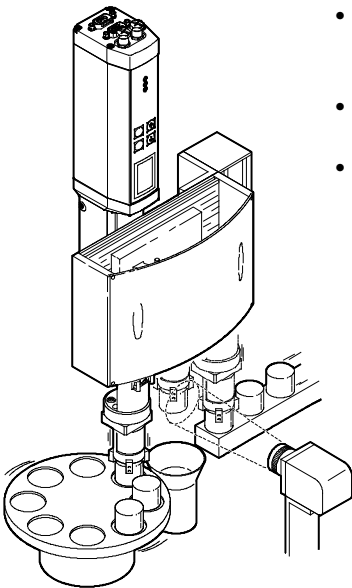

- Flexible pick and place unit with quality inspection of components and ejector for reject parts
- Handling of parts with different heights
- Handling at different speeds, e.g. for linear transfer or rotary indexing table

Rotary indexing table

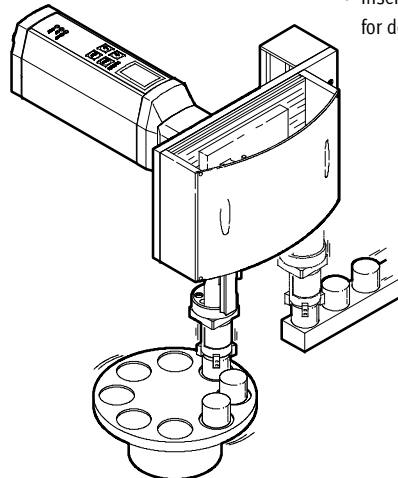

- Adjustable wait position module directly above workpiece/workpiece carrier
- Insertion tasks at different speeds for delicate components

HSP...-AS, without drive

Linear transfer

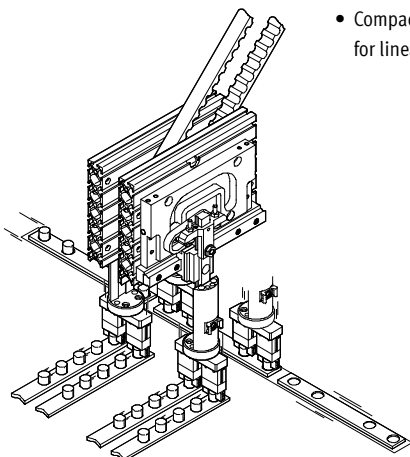

- Compact twin pick and place unit for linear transfer

Rotary indexing table, linear transfer

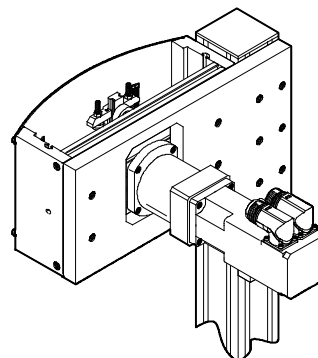

- Fast and flexible pick and place unit with servo motor EMMS-AS
- Electrical variant using third-party motor

Handling modules HSP

Key features at a glance

HSP...-AP – pneumatic with swivel module DSM

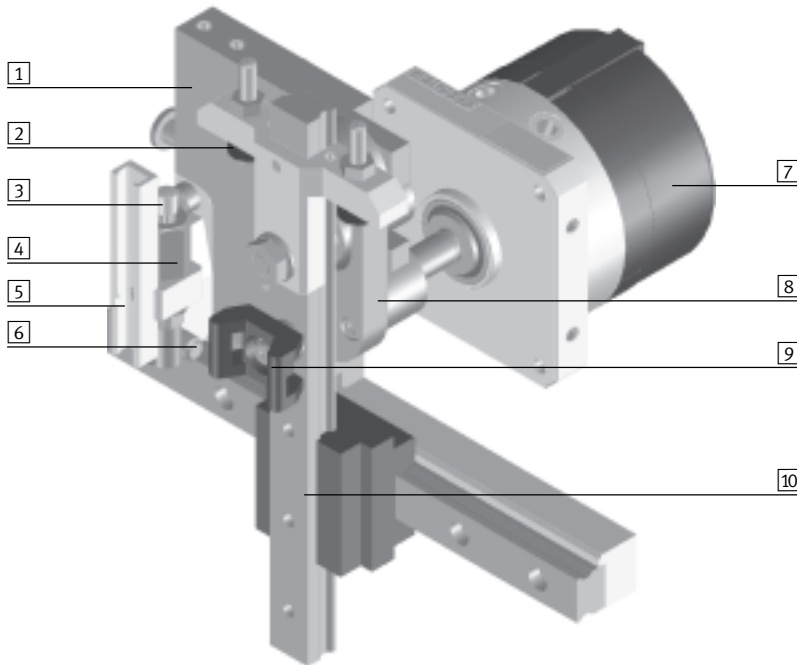

- 1 Slotted guide plate
- 2 Adjustable stop
- 3 Shock absorber YSRW
- 4 Stop sleeve
- 5 Sensor rail
- 6 Pressure piece
- 7 Swivel module DSM
- 8 Swivel lever
- 9 Cable binder holder
- 10 Cross-guide

HSP...-AS – without drive (rear side)

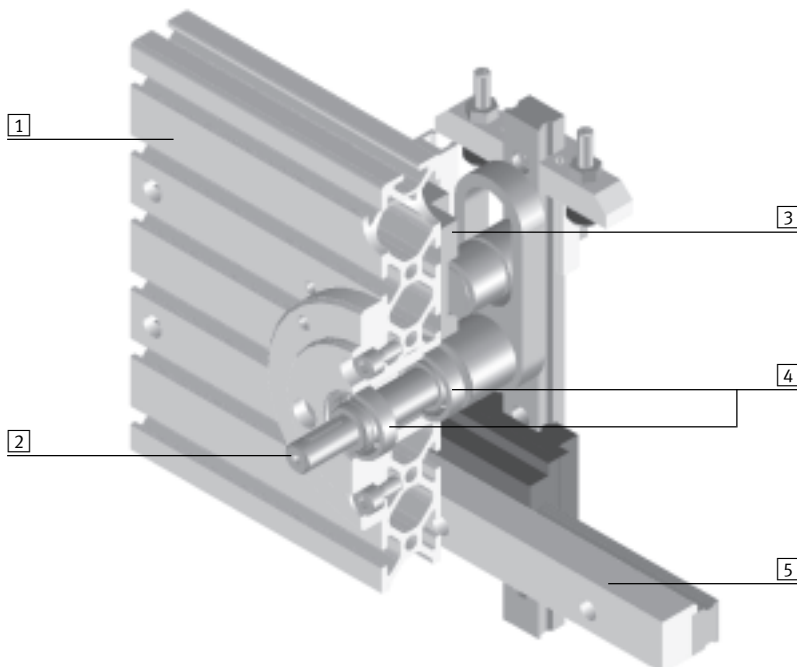

- 1 Back plate
- 2 Shaft with Woodruff key
- 3 Slotted guide plate
- 4 Ball bearings
- 5 Aluminium rail for alignment of slotted guide plates

Handling modules HSP

Key features at a glance

HSP-...-AE – electrical version with servo motor unit MTR-DCI-...-HM

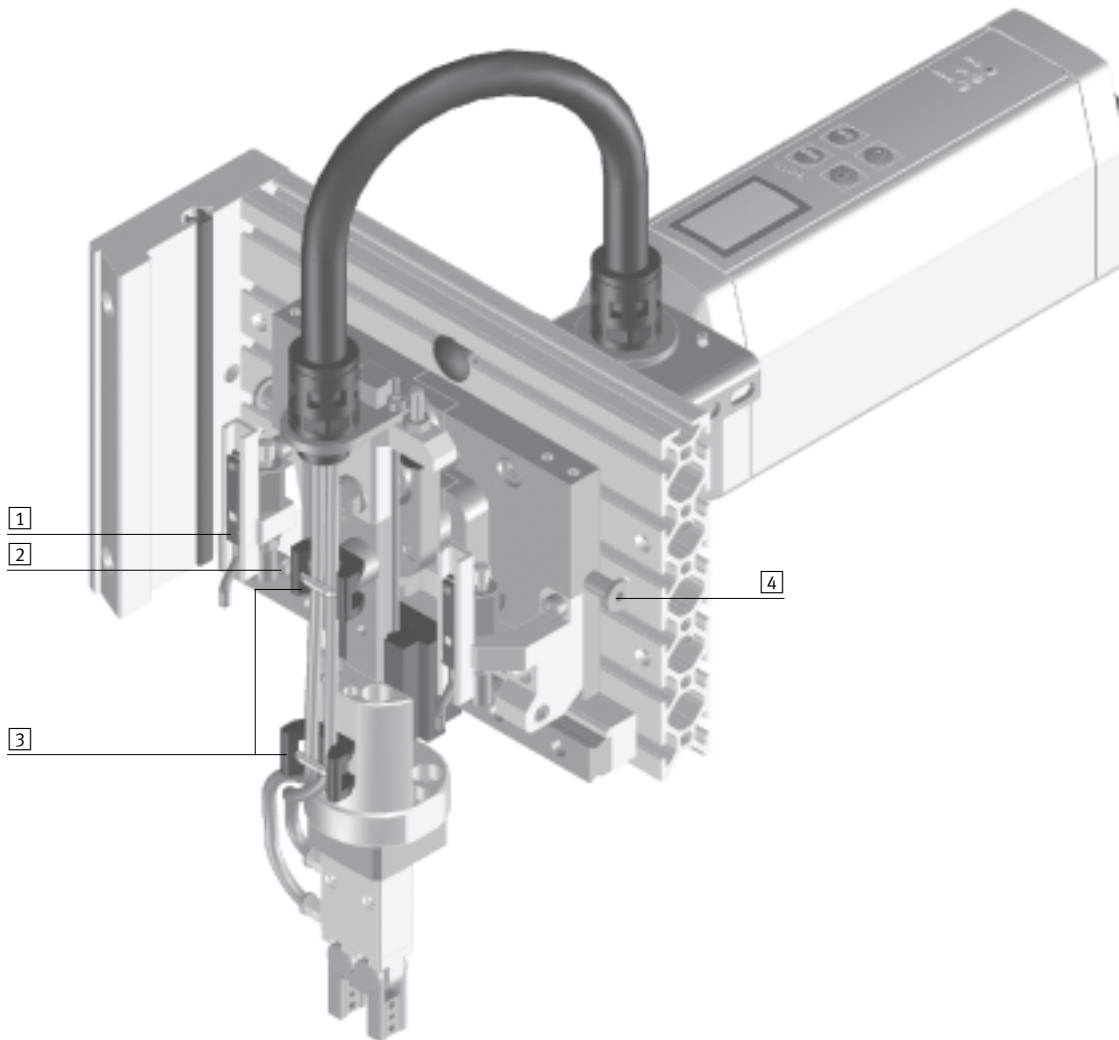

The technology in detail



1 Proximity sensor cables are installed via profile slots in the side and back plate.

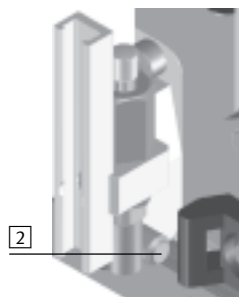

2 The pressure piece guarantees freedom from backlash and precision at the end positions and in the effective linear stroke along the Z-axis.



3 Cable binder holders facilitate the secure routing of tubing and cables.



4 The adjustable slotted guide plate permits precise stroke setting.

Handling modules HSP

Peripherals overview

FESTO

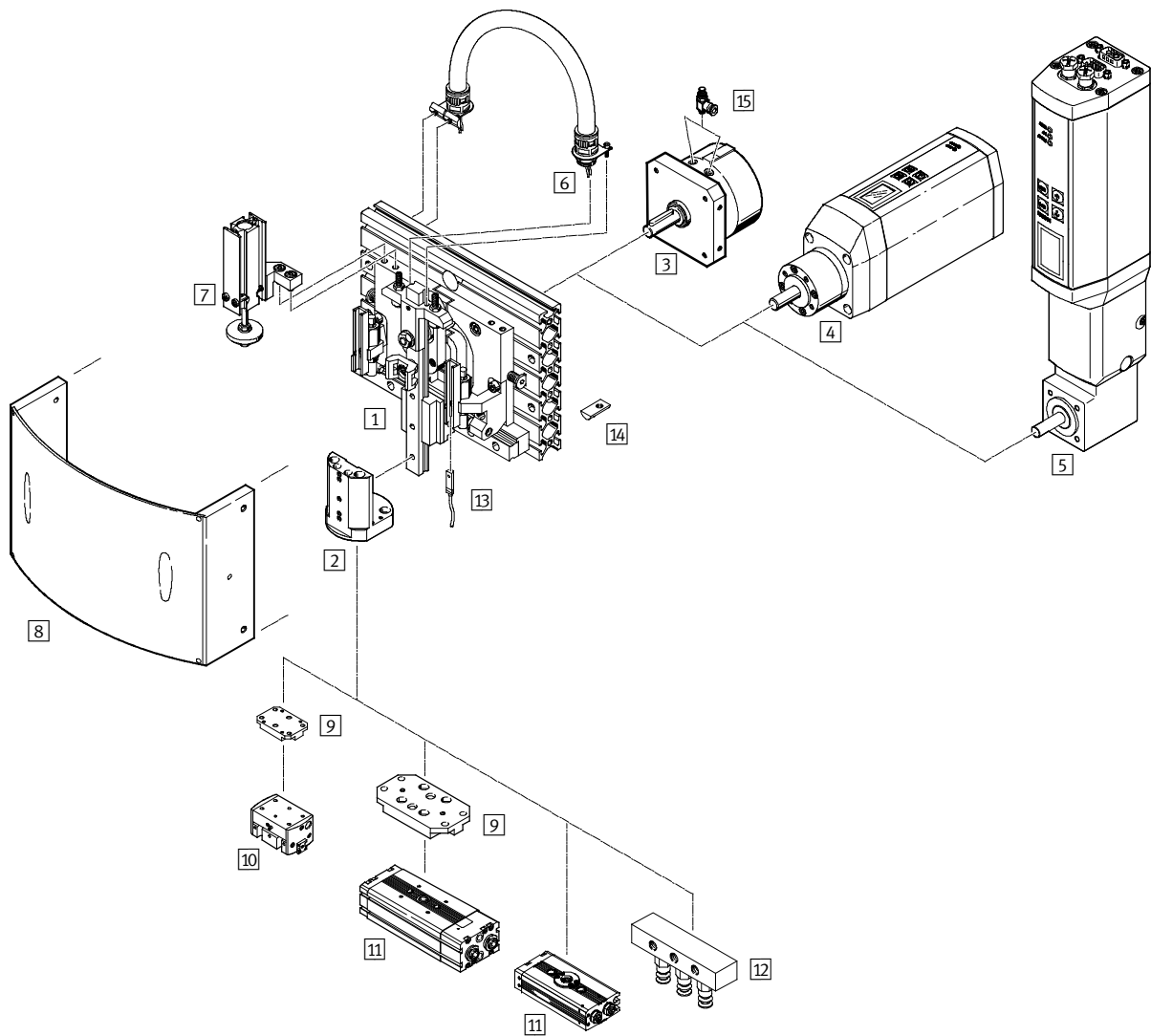

Handling modules HSP

Peripherals overview

Accessories		
	Brief description	→ Page/Internet
1	Handling module HSP	Standard module without accessories 9
2	Adapter kit HAPG	Interface for grippers, semi-rotary drives, etc. 36
3	Swivel module DSM	Pneumatic drive, adapted to each size dsm
4	Motor unit MTR-DCI-...-HM	Servo motor with integrated power electronics 25
5	Motor unit MTR-DCI-...-HM	Servo motor with angle gear unit and integrated power electronics 25
6	Installation kit MKRP	Conduit to protect electric cables and tubing 36
7	Wait position module BWL-/BWR-HSP	With pneumatic drive: Function for retracting the swivel arm from operating area 37
8	Cover kit BSD-HSP	To protect against accidental contact 37
9	Adapter kit	Interface between HSP and gripper or semi-rotary drive gripper drqd
10	Gripper	Parallel/Three-point/Radial/Angle gripper, appropriate gripper for every application gripper
11	Semi-rotary drive DRQD	Semi-rotary drive for transferring parts drqd
12	Suction cups	Appropriate suction cup for every application suction cup
13	Proximity sensor SME-/SMT-8	Sensing facility for end positions 38
14	Slot nut HMBN	Mounting element 39
15	Non-return and flow control valve GRLA	Speed setting of pneumatic drives grla

Handling modules HSP, pneumatic

Type codes

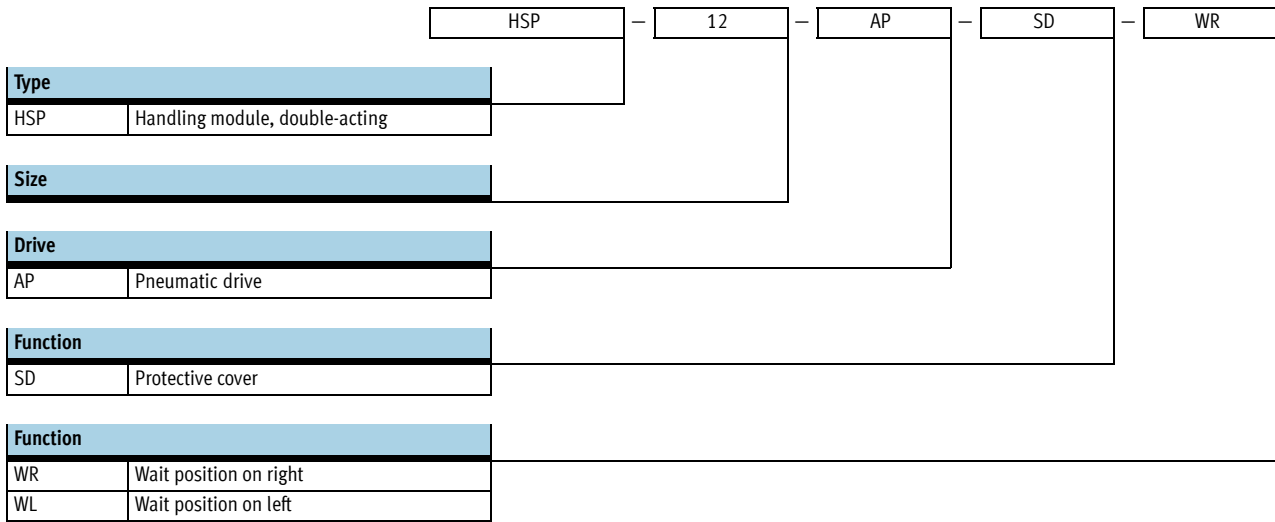

Handling modules HSP, pneumatic

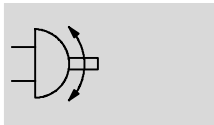

Technical data

Function



 www.festo.com



-  Size
12, 16 and 25
-  Y-stroke length
52 ... 170
-  Z-stroke length
20 ... 70

General technical data	
Type	HSP-...-AP
Pneumatic connection	M5
Mode of operation	Double-acting
Operating medium	Compressed air in accordance with ISO 8573-1:2010 [7:-:-]
Note on operating/pilot medium	Operation with lubricated medium possible (in which case lubricated operation will always be required)
Constructional design	Swivel module
	Cross-guide
	Guided motion sequence
Cushioning	Shock absorber at both ends, soft characteristic curve
Position sensing	For proximity sensing
Type of mounting	With through-holes
	With slot nuts
Mounting position	Guide rail, vertical/horizontal

Operating and environmental conditions	
Type	HSP-...-AP
Operating pressure [bar]	4 ... 8
Ambient temperature [°C]	0 ... +60

Stroke [mm]				
Size		12	16	25
Y-axis				
Stroke		52 ... 68	90 ... 110	130 ... 170
Z-axis				
Stroke	Z	20 ... 30	35 ... 50	50 ... 70
Working stroke	Za	5 ... 15	5 ... 20	5 ... 25

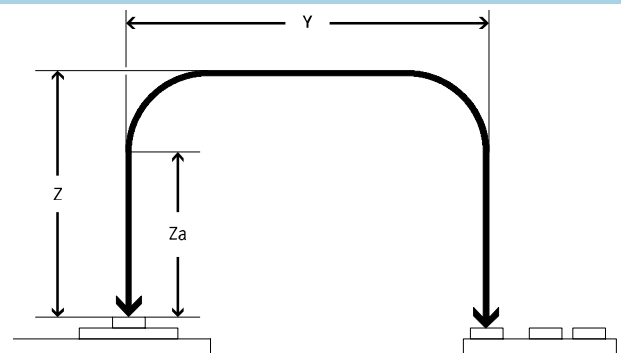

Forces [N]			
Size	12	16	25
Z-axis			
Effective force at 6 bar	40	50	65
Y-axis			
Permissible process force	30	35	50

Handling modules HSP, pneumatic

Technical data

FESTO

Weight [g]			
Size	12	16	25
HSP-...-AP	1900	2900	6400
HSP-...-AP-SD	2600	3400	7600
HSP-...-AP-SD-WR	2800	3600	8100
HSP-...-AP-SD-WL	2800	3600	8100

Repetition accuracy [mm]

To ensure low-vibration operation, the working load should be mounted as close as possible to the guide rail of the handling module. Repetition accuracy is guaranteed by

mounting the working load (adapter plate, rotary drive and/or gripper, gripper finger, workpiece) within the mounting surface of the adapter kit HAPG.

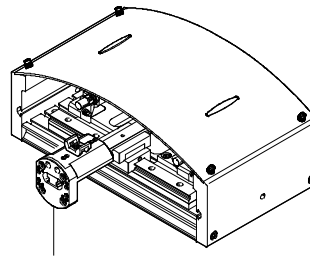

Mounting surface of HAPG

Size	12	16	25
Repetition accuracy at end positions	±0.01	±0.01	±0.02

Travel times t as a function of working load m

The travel time t is the time taken for the handling module to move from one end position to the other and back again.

The working load m is the load attached to the vertical guide rail (e.g. adapter, gripper, semi-rotary drive and workpiece).

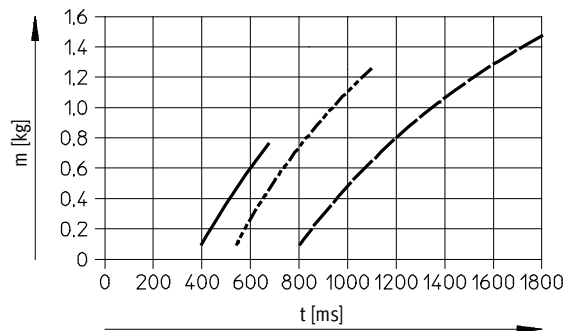

Cycle times [s]

The cycle time t_t comprises the travel time t and the dwell time t_e at the end positions.

$t_t = \text{travel time } t + \text{dwell time } t_e$
The value must not fall below the minimum cycle time.

Size	12	16	25
Min. cycle time	0.6	0.8	1.0

Example for HSP-12-AP

Step 1:
The following values are assumed:
Working load $m = 0.15 \text{ kg}$
Dwell time $t_e = 2 \times 50 \text{ ms}$
(50 ms per end position)

Step 2:
The travel time can be determined from the graph:
 $t = 400 \text{ ms}$

Step 3:
This gives us a cycle time:
 $t_t = 400 \text{ ms} + 100 \text{ ms} = 500 \text{ ms}$

Step 4:
The table gives us a min. cycle time of 600 ms. This means that the movement has to be controlled.

Handling modules HSP, pneumatic

Technical data

Permissible static/dynamic characteristic load values

Cross-guide

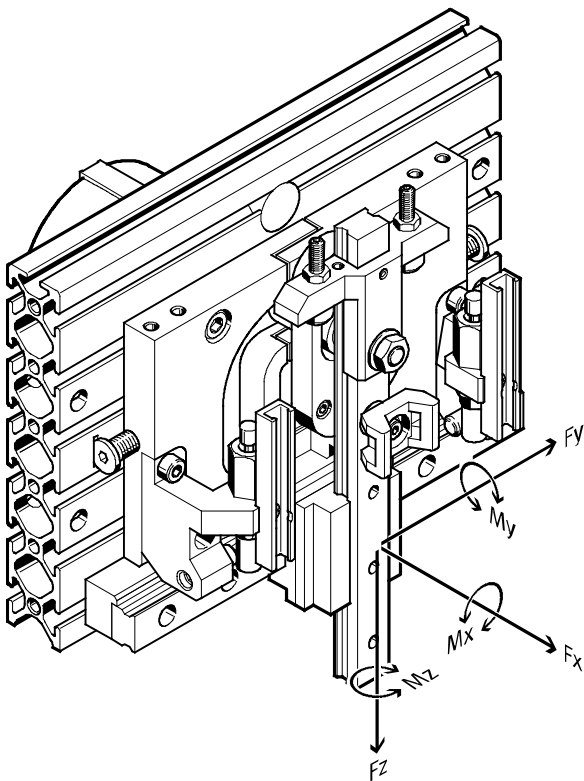

- - Note

The torques apply to the centre of the vertical guide.

Combined load

The following torque equation must be satisfied with combined load:

$$\frac{M_x}{M_{xperm.}} + \frac{M_y}{M_{yperm.}} + \frac{M_z}{M_{zperm.}} \leq 1$$

Dynamic characteristic load values			
Size	12	16	25
Max. torques [Nm]	1.1	2.4	3.2
$M_{xperm.}, M_{yperm.}, M_{zperm.}$			

Combined load

The following torque equation must be satisfied with combined load:

$$\frac{M_{ox}}{M_{oxperm.}} + \frac{M_{oy}}{M_{oyperm.}} + \frac{M_{oz}}{M_{ozperm.}}$$

Static characteristic load values			
Size	12	16	25
Max. torques [Nm]	5	10	15
$M_{oxperm.}, M_{oyperm.}, M_{ozperm.}$			

Handling modules HSP, pneumatic

Technical data

FESTO

Stroke adjustment

Y stroke:

- Once the HSP has been mounted, the Y strokes of the pick and place position can be set independently of each other.

Z stroke:

- Differences in height, for example between a rotary indexing table and a transfer system, can be compensated after mounting.

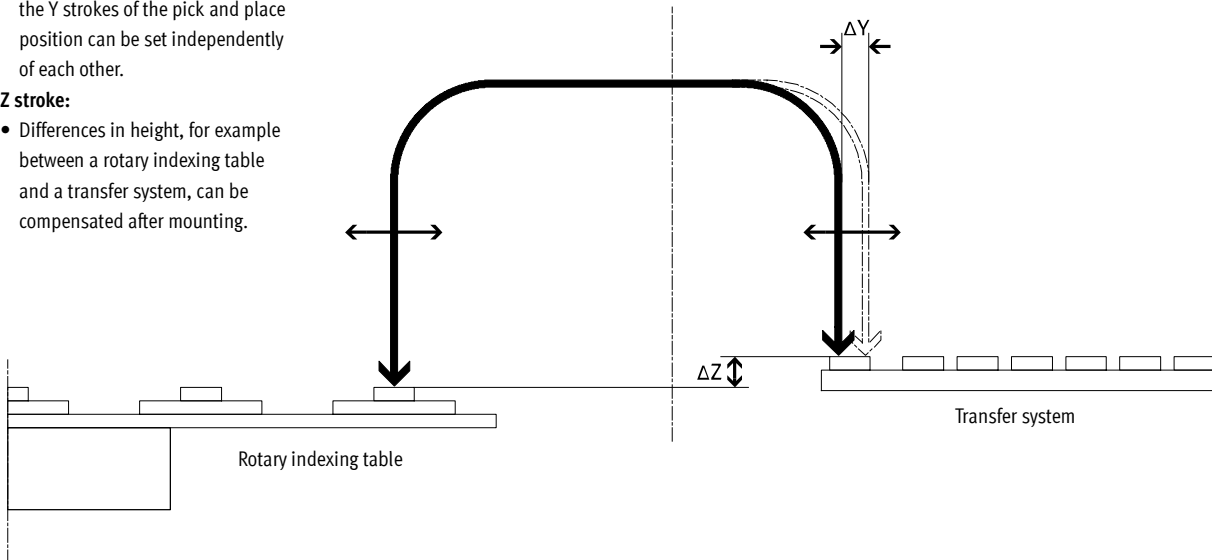

Y-axis (horizontal)

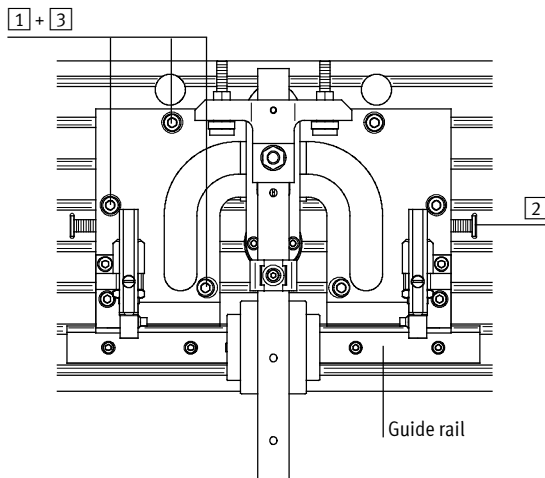

Procedure:

- Loosen the screws
- Adjust the slotted guide plate using the adjustment screw (the slotted guide plate must always make contact with the guide rail)
- Tighten the screws

Z-axis (vertical)

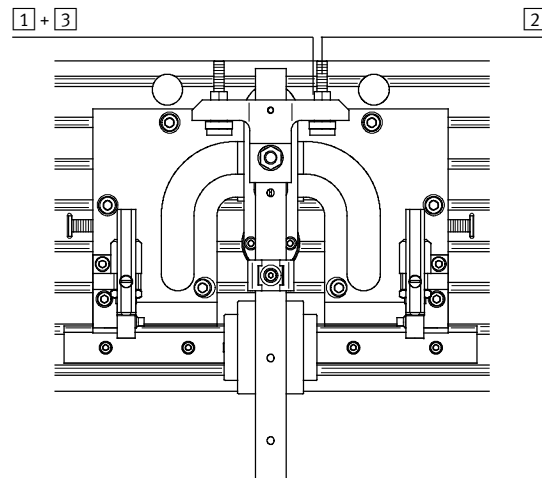

Procedure:

- Loosen the lock nut
- Set the desired Z stroke using the set screw
- Tighten the lock nut

Handling modules HSP, pneumatic

Technical data

Wait position module

Application and mode of operation

Figure 1:

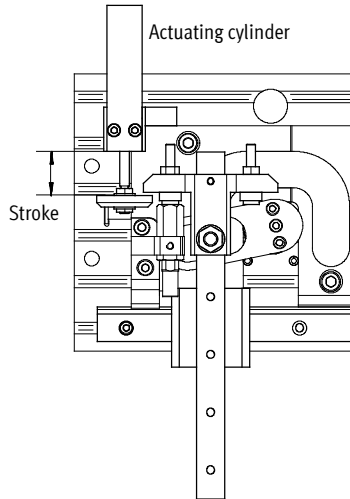
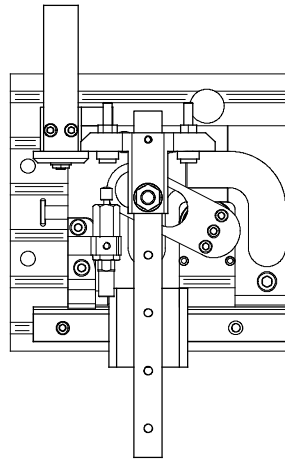
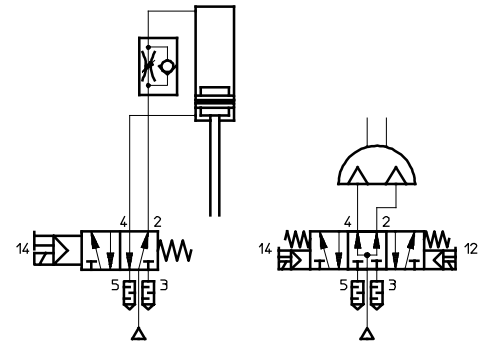

Figure 2:



Circuit diagram for HSP with wait position module



- 1 The handling module HSP is at the right-hand end position. The actuating cylinder is extended in its initial position.
- 2 The 5/3-way valve is reset once the handling module reaches the left-hand end position. (Figure 1)
- 3 During retraction, the actuating

cylinder pulls the handling module upwards to its wait position. The operating area is then free. (Figure 2)

- 4 From the wait position, the handling module can move either to the initial position or to the other end position.

Cycle

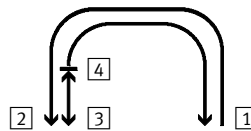

Note
When used in combination with the wait position module, the handling module HSP must be actuated using a 5/3-way valve (normally pressurised). The actuating cylinder is actuated using a 5/2-way valve. The actuating cylinder may only be used for "pulling" applications.

Size	HSP-12	HSP-16	HSP-25
Max. Z stroke of wait position module	15	25	25

Mounting options

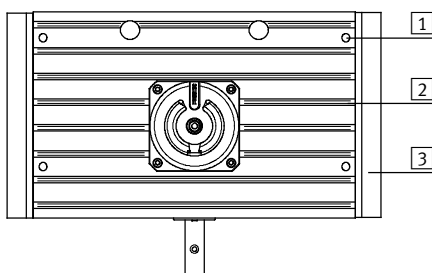

- 1 Direct mounting via through-holes
- 2 Via slot nuts
- 3 User-specific

Examples:

With adapter kit HMBV

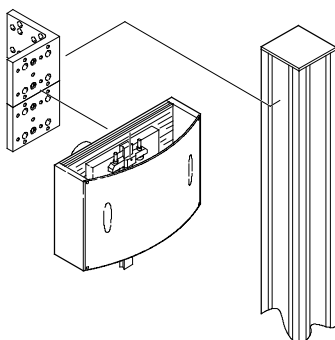

User-specific

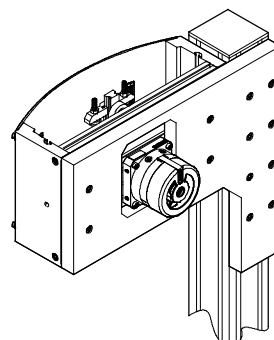

Handling modules HSP, pneumatic

Technical data

FESTO

Materials

Sectional view of handling module HSP

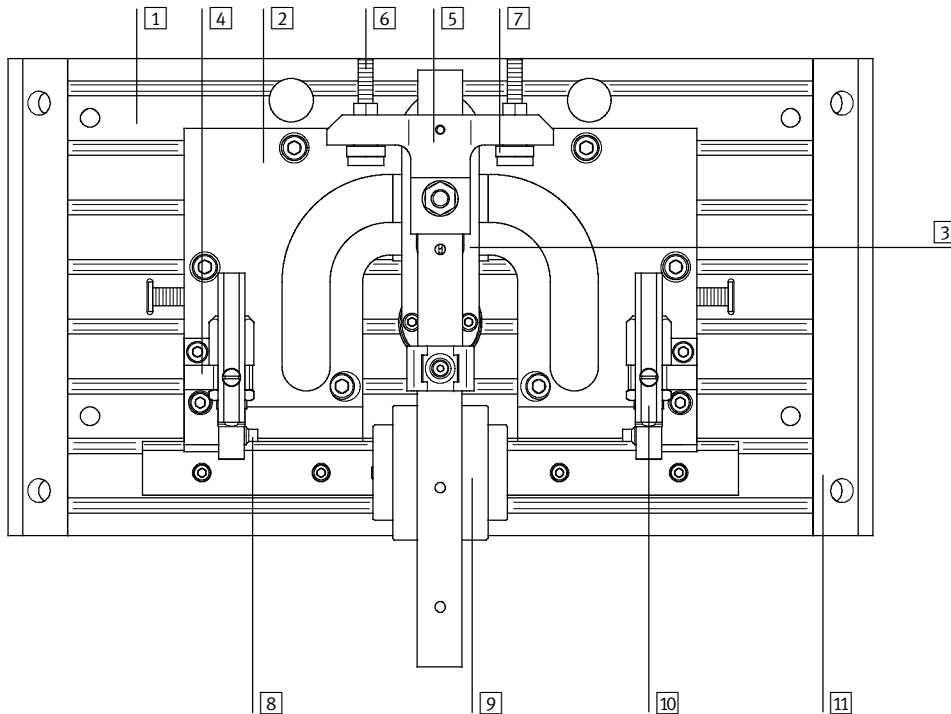

Handling module		
1	Back plate	Wrought aluminium alloy, anodised
2	Slotted guide plate	Case-hardened steel, burnished
3	Swivel lever	Case-hardened steel, burnished
4	Retainer	Wrought aluminium alloy, anodised
5	Flange	Wrought aluminium alloy, anodised
6	Adjusting screw	High-alloy steel
7	Stop sleeve	High-alloy steel
8	Pressure piece	High-alloy steel
9	Cross-guide	Tempered steel
10	Sensor rail	Wrought aluminium alloy, anodised
11	Housing	Wrought aluminium alloy, anodised
Material note		Copper, PTFE and silicone-free

Handling modules HSP, pneumatic

Technical data

Materials

Sectional view of swivel module DSM

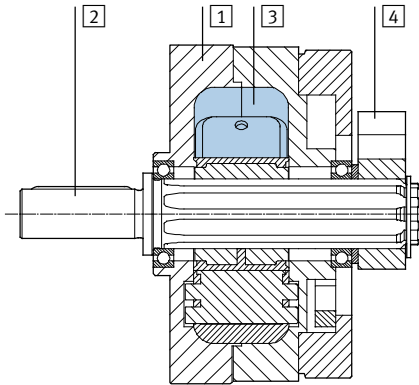

Swivel module		
1	Housing	Wrought aluminium alloy
2	Shaft	Steel with nickel-plated surface
3	Rotary vane	Fibreglass reinforced plastic
4	Stop lever	Anodised aluminium
-	Cap	Fibreglass reinforced plastic
-	Seals	Polyurethane
-	Material note	Copper, PTFE and silicone-free

Handling modules HSP, pneumatic

Technical data

FESTO

Dimensions

Download CAD data → www.festo.com

With swivel module DSM

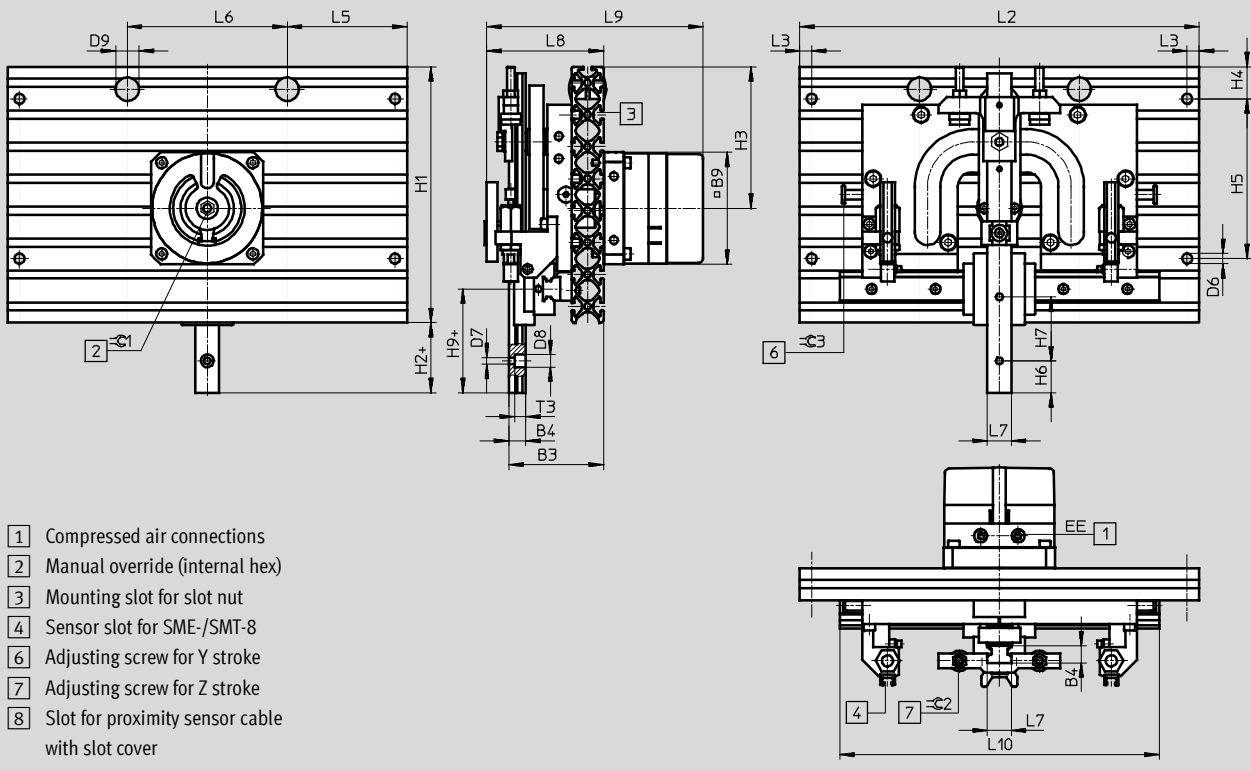

With swivel module DSM and protective cover

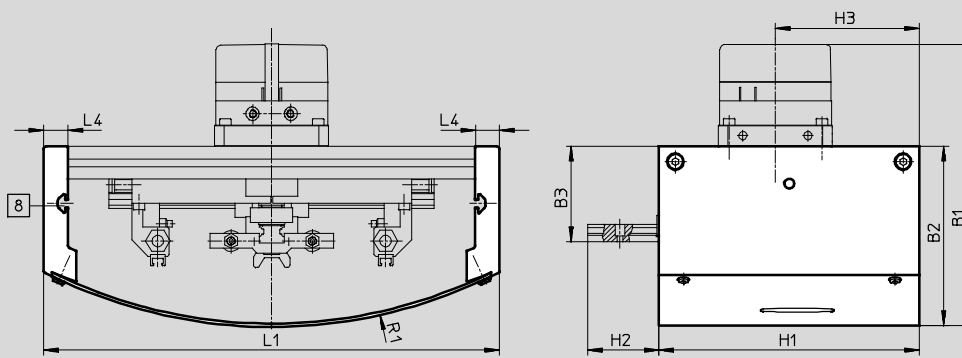

With wait position on right

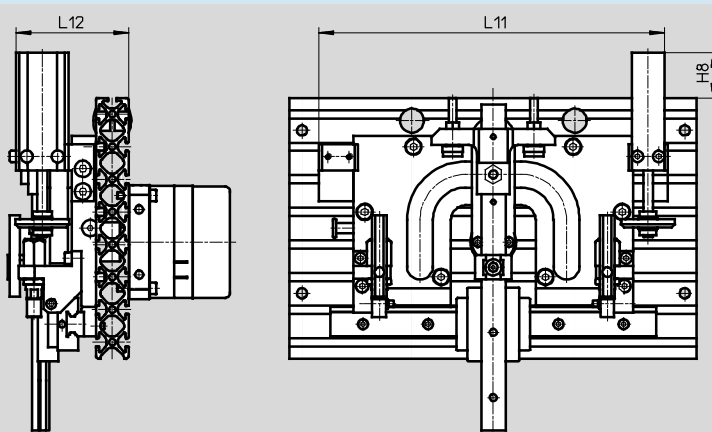

Handling modules HSP, pneumatic

Technical data

Size	B1 ±3	B2 ±2	B3 ±0.5	B4	B9	D6 ∅	D7 ∅	D8 ∅	D9 ∅
12	150	93	56	9 ^{-0.03}	56	6.3	3.5	6.2	13
16	179	111	60	10.6 ^{-0.03}	70	6.3	4.3	8	13
25	188	115	62	10 ±0.05	83	6.3	4.5	10	13

Size	EE	H1	H2 ±0.2	H3	H4	H5 ±0.2	H6	H7	H8
12	M5	120	34	66	40	40	12.5	25	30
16	M5	160	44	88.5	20	100	20	40	33
25	M5	200	75	110	40	100	20	30	13

Size	H9	L1 ±0.6	L2 ±0.2	L3	L4	L5	L6	L7	L8 ±1.2
12	44	200	170	7.5	15	85	–	12 ^{-0.01/-0.05}	65
16	65	280	250	7.5	15	75	100	15 ^{-0.01/-0.05}	73
25	101	370	340	7.5	15	30	280	23.2 ±0.05	80

Size	L9 ±3	L10	L11 ¹⁾	L12	R1	T3	≈C1	≈C2	≈C3
12	122	150	141.5	64	200	6	6	2	3
16	142	200	210	69	306	6.5	8	2.5	3
25	153	250	277	79	484	6.3	8	2.5	4

1) If the Y stroke is increased, the change in stroke must be added to the dimension.

Ordering data for HSP-...-AP									
Size	12		16		25				
	Part No.	Type	Part No.	Type	Part No.	Type			
Without protective cover									
–	533 599	HSP-12-AP	533 607	HSP-16-AP	533 615	HSP-25-AP			
Wait position on right	533 603	HSP-12-AP-WR	533 611	HSP-16-AP-WR	533 619	HSP-25-AP-WR			
Wait position on left	533 604	HSP-12-AP-WL	533 612	HSP-16-AP-WL	533 620	HSP-25-AP-WL			
With protective cover									
–	533 600	HSP-12-AP-SD	533 608	HSP-16-AP-SD	533 616	HSP-25-AP-SD			
Wait position on right	533 601	HSP-12-AP-SD-WR	533 609	HSP-16-AP-SD-WR	533 617	HSP-25-AP-SD-WR			
Wait position on left	533 602	HSP-12-AP-SD-WL	533 610	HSP-16-AP-SD-WL	533 618	HSP-25-AP-SD-WL			

Handling modules HSP, electric

Type codes

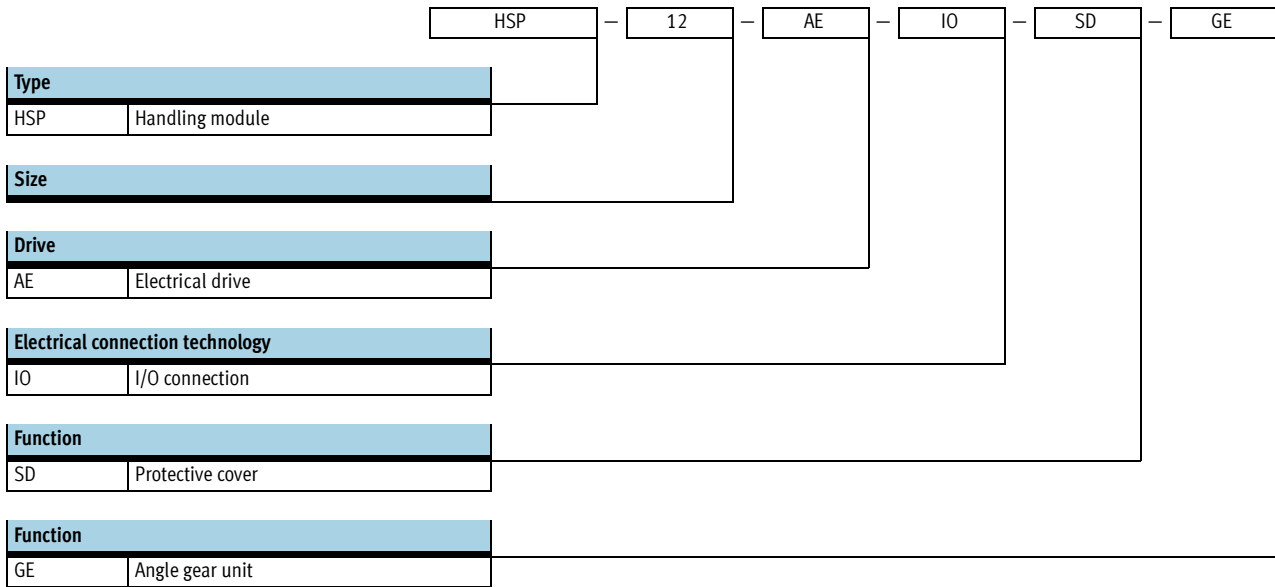

Handling modules HSP, electric

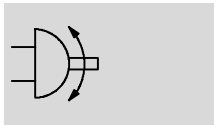

Technical data

Function



 www.festo.com



-  Diameter
12, 16 and 25
-  Y-stroke length
52 ... 170
-  Z-stroke length
20 ... 70

General technical data	
Type	HSP-...-AE
Constructional design	Motor unit
	Cross-guide
	Guided motion sequence
Cushioning	Noise reduction via buffers
Type of mounting	With through-holes
	With slot nuts
Mounting position	Guide rail, vertical/horizontal

Operating and environmental conditions	
Type	HSP-...-AE
Ambient temperature [°C]	0 ... +50
Protection class handling module	IP40
Protection class motor	IP54
CE marking (see declaration of conformity)	In accordance with EU EMC directive

Stroke [mm]				
Size	12	16	25	
Y-axis				
Stroke	52 ... 68	90 ... 110	130 ... 170	
Z-axis				
Stroke	Z	20 ... 30	35 ... 50	50 ... 70
Working stroke	Za	5 ... 15	5 ... 20	5 ... 25

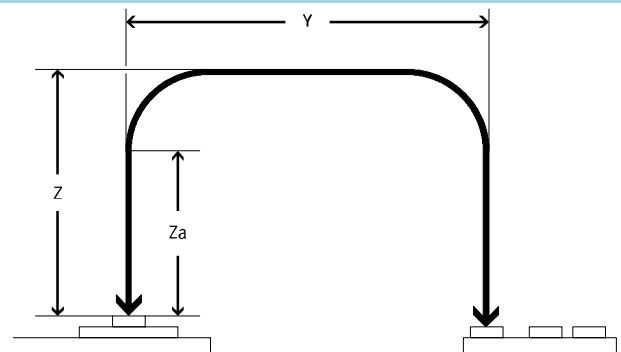

Forces [N]						
Size	12		16		25	
Stroke [mm]	52	68	90	110	130	170
Z-axis						
Effective force at 40% of drive torque (preset)	10		10		15	
Max. effective force relative to stroke	22	17	24	20	48	36
Y-axis						
Permissible process force	30		35		50	

Handling modules HSP, electric

Technical data

Weight [g]			
Size	12	16	25
HSP-...-AE	3700	5300	9000
HSP-...-AE-SD	4500	6600	10700
HSP-...-AE-GE	4000	5700	10100
HSP-...-AE-SD-GE	4800	7000	11800

Repetition accuracy [mm]

To ensure low-vibration operation, the working load should be mounted as close as possible to the guide rail of the handling module. Repetition accuracy is guaranteed by

mounting the working load (adapter plate, rotary drive and/or gripper, gripper finger, workpiece) within the mounting surface of the adapter kit HAPG.

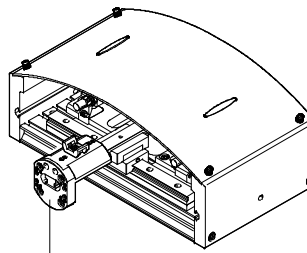

Mounting surface of HAPG

Size	12	16	25	
Repetition accuracy	At end positions Intermediate positions	± 0.01 < 1.5	± 0.01 < 1.5	± 0.02 < 2

Travel times t as a function of working load m

The travel time t is the time taken for the handling module to move from one end position to the other and back again.

The working load m is the load attached to the vertical guide rail (e.g. adapter, gripper, semi-rotary drive and workpiece)

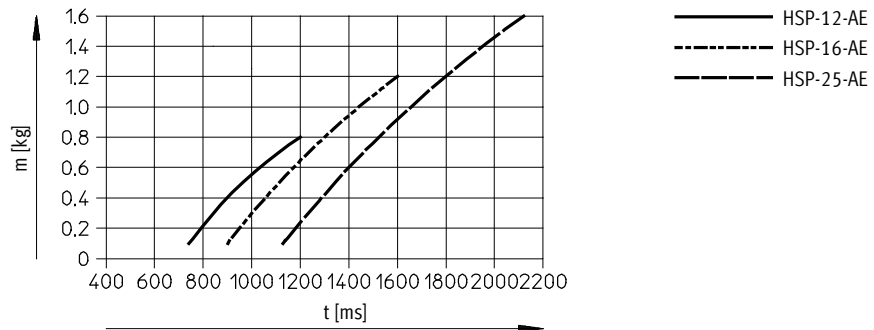

Handling modules HSP, electric

Technical data

Permissible static/dynamic characteristic load values

Cross-guide

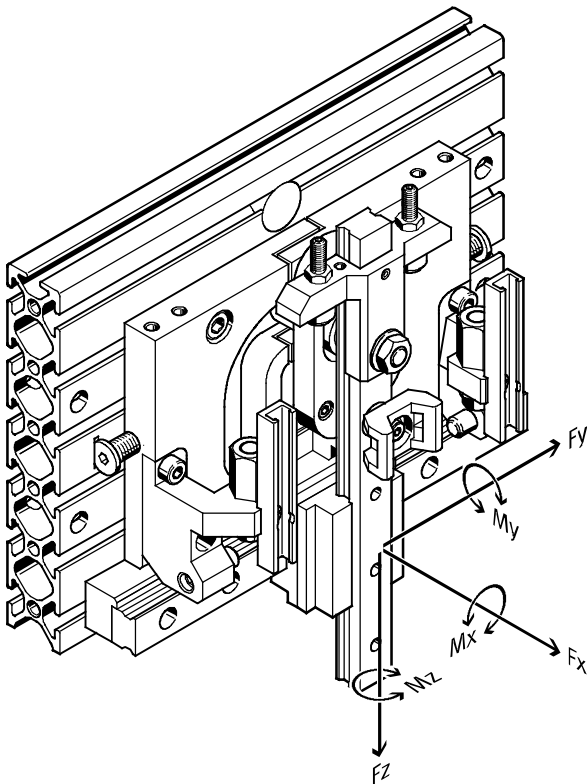

- - Note

The torques apply to the centre of the vertical guide.

Combined load

The following torque equation must be satisfied with combined load:

$$\frac{M_x}{M_{xperm.}} + \frac{M_y}{M_{yperm.}} + \frac{M_z}{M_{zperm.}} \leq 1$$

Dynamic characteristic load values

Size	12	16	25
Max. torques [Nm] $M_{xperm.}, M_{yperm.}, M_{zperm.}$	1.1	2.4	3.2

Combined load

The following torque equation must be satisfied with combined load:

$$\frac{M_{ox}}{M_{oxperm.}} + \frac{M_{oy}}{M_{oyperm.}} + \frac{M_{oz}}{M_{ozperm.}}$$

Static characteristic load values

Size	12	16	25
Max. torques [Nm] $M_{oxperm.}, M_{oyperm.}, M_{ozperm.}$	5	10	15

Stroke adjustment

Y stroke:

- Once the HSP has been mounted, the Y strokes of the pick and place position can be set independently of each other.

Z stroke:

- Differences in height, for example between a rotary indexing table and a transfer system, can be compensated after mounting.

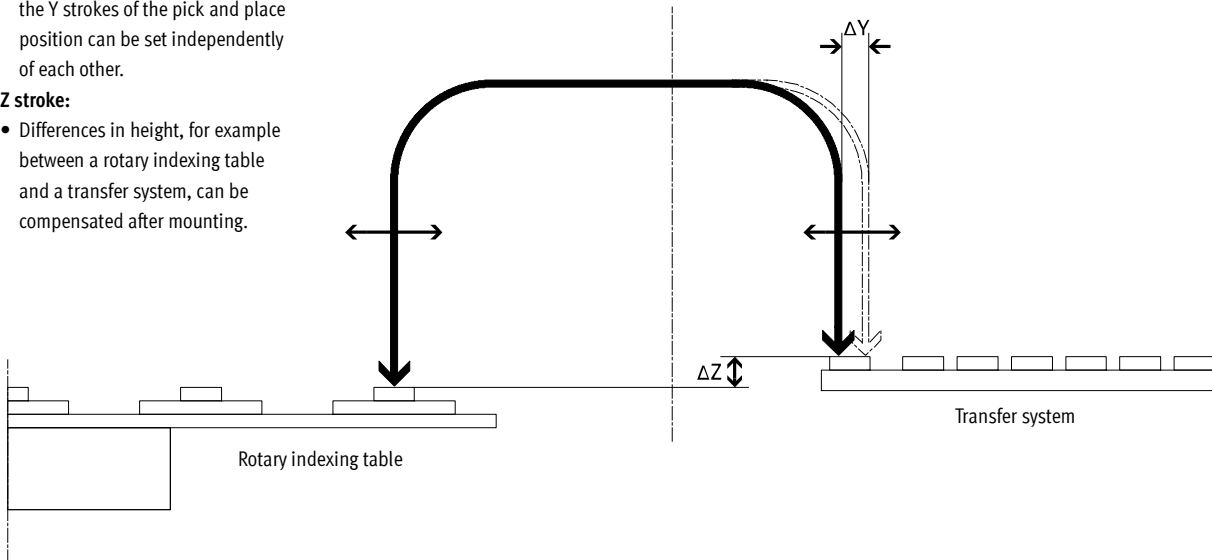

Y-axis (horizontal)

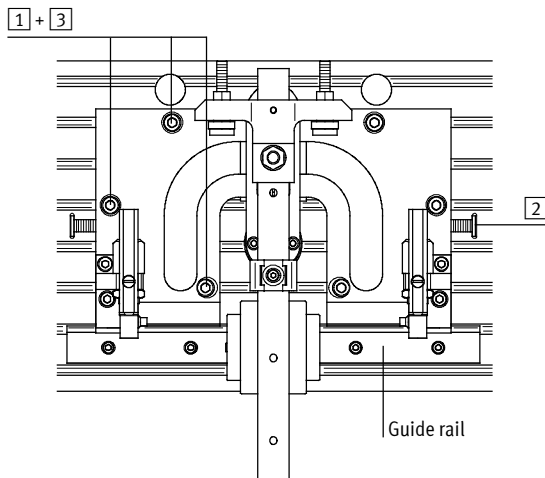

Procedure:

- Loosen the screws
- Adjust the slotted guide plate using the adjustment screw (the slotted guide plate must always make contact with the guide rail)
- Tighten the screws

Z-axis (vertical)

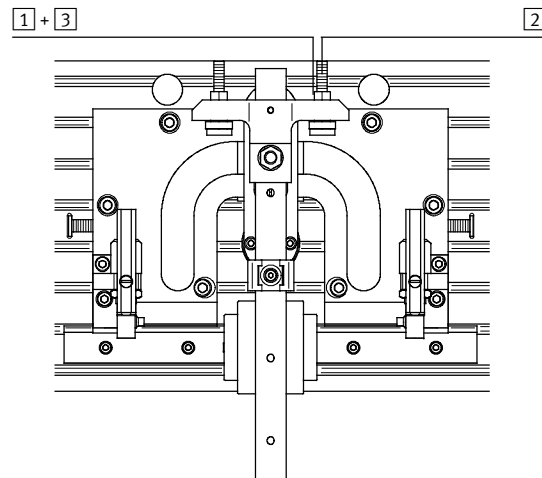

Procedure:

- Loosen the lock nut
- Set the desired Z stroke using the set screw
- Tighten the lock nut

Handling modules HSP, electric

Technical data

Materials

Sectional view

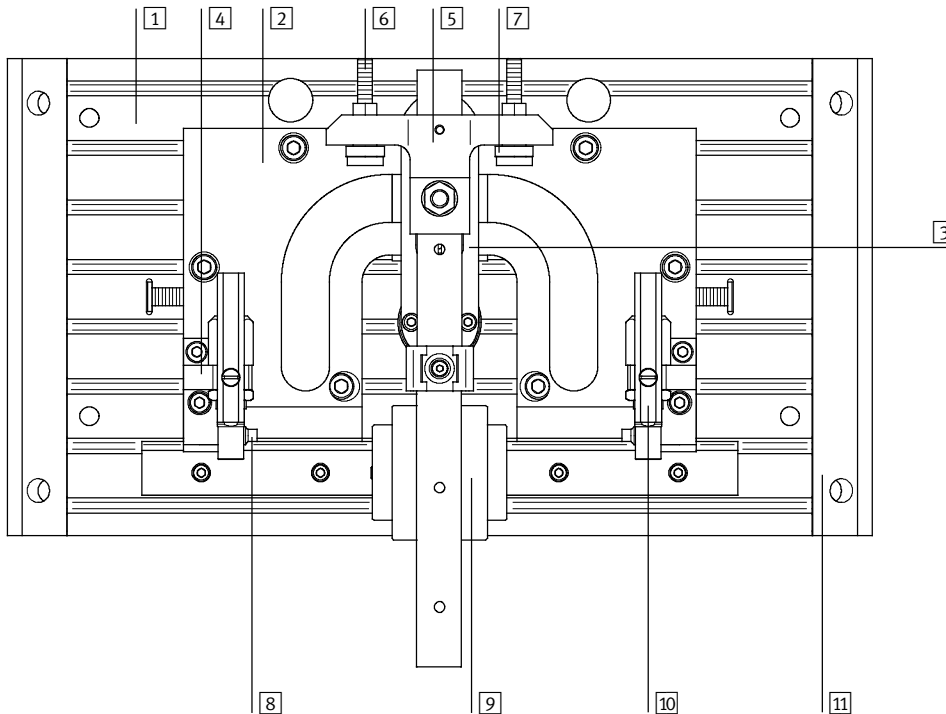

Handling module		
1	Back plate	Wrought aluminium alloy, anodised
2	Slotted guide plate	Case-hardened steel, burnished
3	Swivel lever	Case-hardened steel, burnished
4	Retainer	Wrought aluminium alloy, anodised
5	Flange	Wrought aluminium alloy, anodised
6	Adjusting screw	High-alloy steel
7	Stop sleeve	High-alloy steel
8	Pressure piece	High-alloy steel
9	Cross-guide	Tempered steel
10	Sensor rail	Wrought aluminium alloy, anodised
11	Housing	Wrought aluminium alloy, anodised
Material note		Copper, PTFE and silicone-free

Handling modules HSP, electric

Technical data

Motor mounting variants

Motor pointing upwards/to side

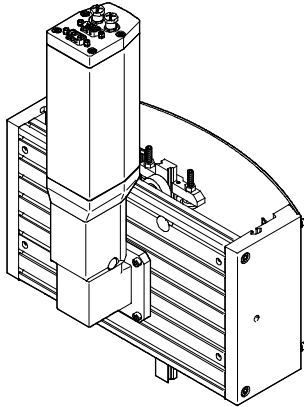

Control panel and access to the connections can be rotated according to space requirements.

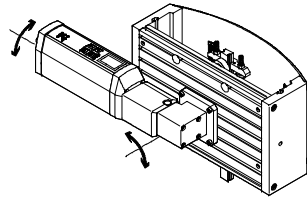

Motor towards rear

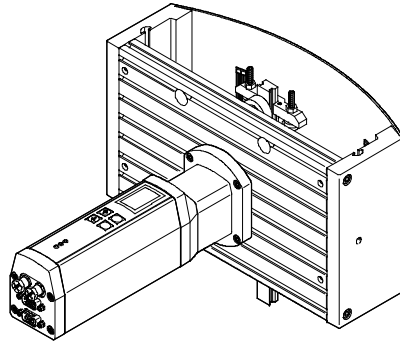

Mounting options

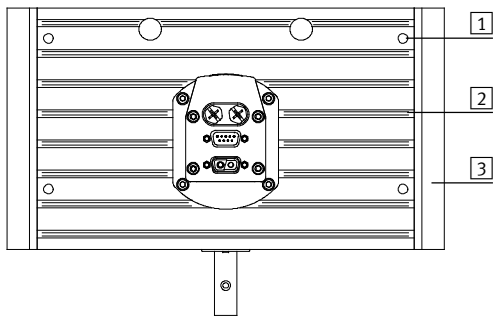

- 1 Direct mounting via through-holes
- 2 Via slot nuts
- 3 User-specific

Examples:

With adapter kit HMBV

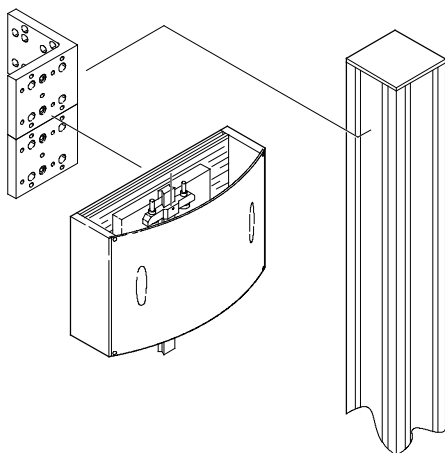

User-specific

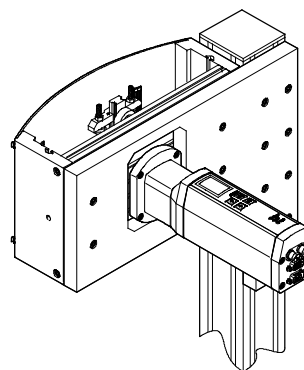

Handling modules HSP, electric

Technical data

FESTO

Servo-motor unit MTR-DCI-...-HM



General technical data		→ Internet: mtr-dci
Type	MTR-DCI-...	
for handling module	HSP-12-AE	HSP-16/25-AE
Rotary position generator	Optical encoder	
No. of increments/revolution	500	
Temperature monitoring	Silicon absolute temperature sensor, switches off at temperatures >70 °C	
Display resolution	128 x 64 pixels	
Type of mounting	Can be screwed on or clamped to gearing flange	
Gearing type	Planetary gear unit	
Gear unit ratio	6.752 (7:1); 1-stage	13.73 (14:1); 2-stage

Electrical data		→ Internet: mtr-dci	
Type	MTR-DCI-42-HM	MTR-DCI-52-HM	
for handling module	HSP-12/16-AE	HSP-25-AE	
Nominal voltage	[V DC]	24 ±10%	24 ±10%
Nominal current (motor)	[A]	2	5.1
Peak current	[A]	3.8	7.7
Nominal power (motor)	[W]	48	122.4
Max. current (digital logic outputs)	[mA]	200	60
No. of digital logic inputs (with I/O connection)	-	6	
No. of digital logic outputs (with I/O connection)	-	2	
Parameterisation interface	RS232, 9600 baud		

Pin allocation

1 3-pin M8 socket	
Pin	Function
1	Unused
3	Unused
4	Unused
-	

2 RS 232 interface, 4-pin M8 socket	
Pin	Function
1	0 V
2	Transmitted Data (TxD)
3	Received Data (RxD)
4	-

3 I/O interface, 9-pin SUB-D plug	
Pin	Function
1	Travel time coding, bit 0
2	Travel time coding, bit 1
3	Travel time coding, bit 2
4	Travel time coding, bit 3
5	Start bit
6	Enable bit
7	Ready signal output
8	MC signal output
9	0 V

4 Power supply, 2-pin plug	
Pin	Function
1	24 V DC
2	0 V
-	
-	
-	
-	
-	
-	

Handling modules HSP, electric

Technical data



Simple solution for your application

Advantages of handling module HSP-...-AE – Installation and commissioning

- Handling module is supplied with motor already attached.
- Less wiring required thanks to integration of controller concept.
- Motor with gear unit, controller and power electronics are all fitted in one housing. This means that only one unit has to be taken into consideration when planning the system.
- Only one voltage supply of 24 V is required for commissioning.
- Commissioning via:
 - control panel on handling module
 - PC using FESTO Configuration Tool (FCT) software

Installation and commissioning

Step 1: Mount the handling module

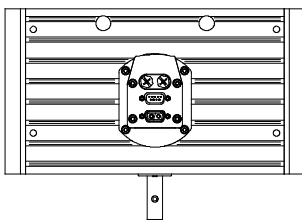

- Wide choice of mounting options

→ 24

Step 2: Mechanically adjust the end positions

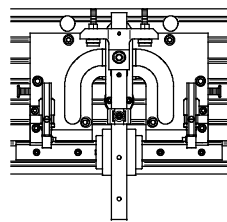

- End positions of strokes along Y- and Z-axes can be adjusted independently of each other

→ 22

Step 3: Connect the 24 V voltage supply

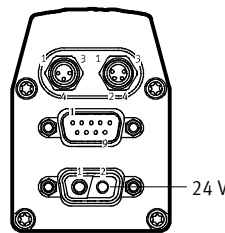

- Plug and work: Connect voltage – HSP is ready for operation

→ 25

Step 4: Parameterisation either via control panel on motor or using FCT software
Control panel on motor

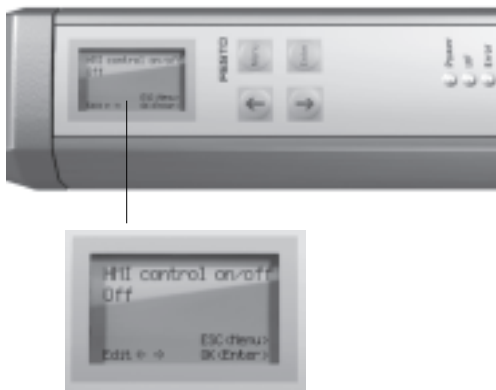

- Clearly arranged LCD display
- All data is entered and saved using 4 keys:
 - menu key
 - arrow keys for changing parameter values or traversing records
 - key for confirming the entered actions

FCT software – Festo Configuration Tool

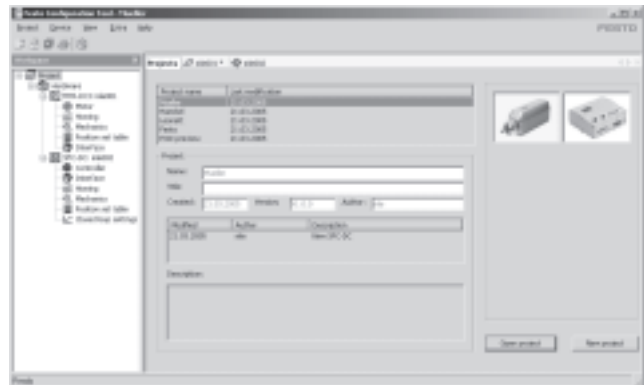

- All the drives in a system can be managed and archived in the common project
- Project and data management for all supported device types
- Simple to use thanks to graphically supported parameter entry
- Universal mode of operation for all drives
- Working offline at your desk or online at the machine

Handling modules HSP, electric

Technical data

Step 5: Selection of predefined motion sequences (HSP mode) via the control panel or using the FCT software

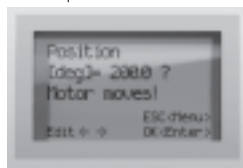

HSP mode 1



- Precise travel to the mechanical end position

HSP mode 2

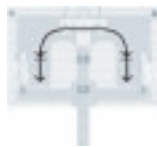

- Additional adjustable wait position module directly above workpiece/ workpiece carrier
- Handling of parts with different heights
- Insertion procedures at different speeds

HSP mode 3



- Additional ejector station for reject parts or quality inspection
- Precise travel to end position with setup position

HSP mode 4



- Insertion procedures with defined force
- Continued travel from wait position with adjustable torque

HSP mode 5



- Insertion procedures with defined force and additional intermediate position
- Continued travel from wait position with adjustable torque

Step 6: Fine adjustment

- Adjustment of preset positions, speeds and torques
- Addition of new traversing records (where necessary)

Handling modules HSP, electric

Technical data

FESTO

Dimensions

Download CAD data → www.festo.com

With motor unit pointing upwards

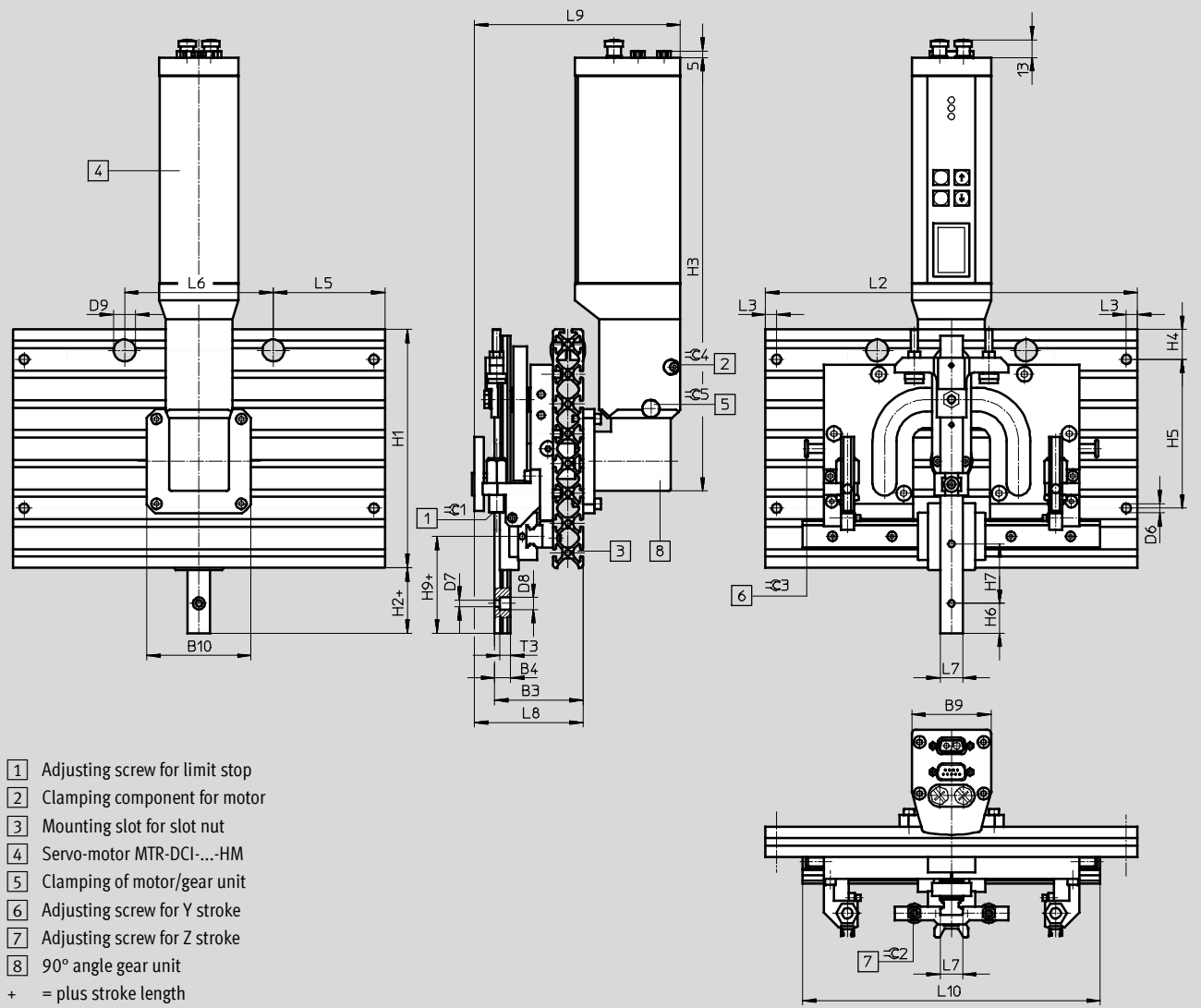

With motor unit pointing sideways

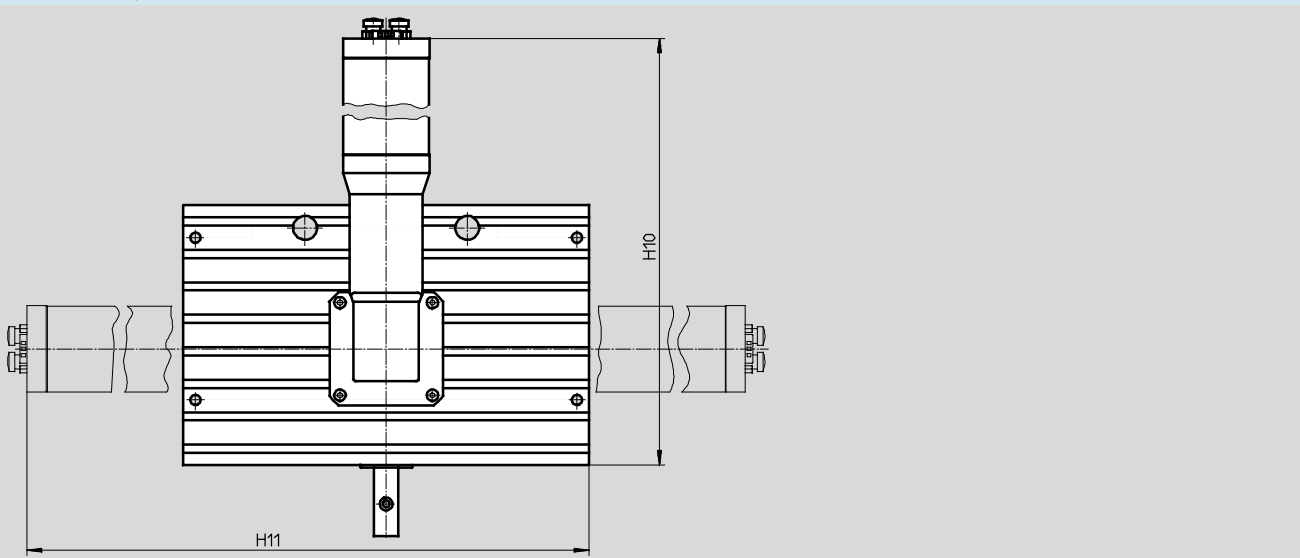

Handling modules HSP, electric

Technical data

FESTO

Dimensions

Download CAD data → www.festo.com

With motor unit pointing upwards and protective cover

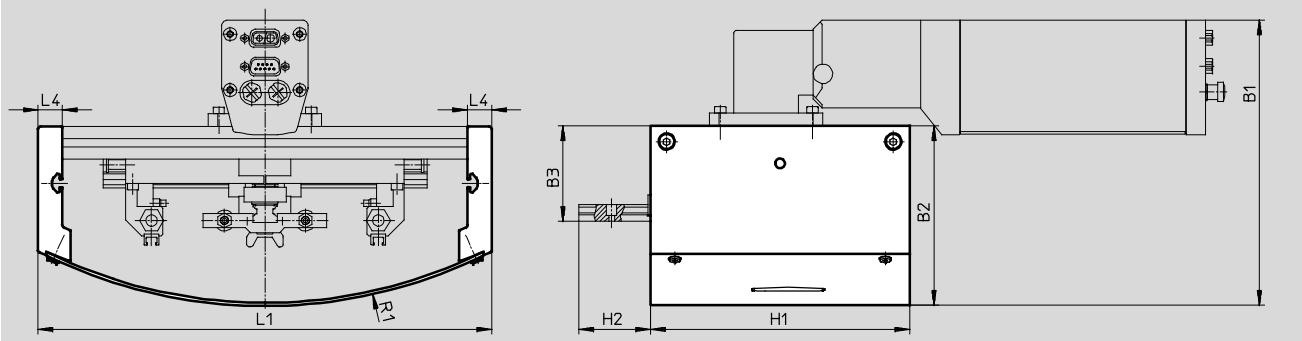

Size	B1 ±3	B2 ±2	B3 ±0.5	B4	B9	B10	D6 ∅	D7 ∅	D8 ∅
12	159	93	56	9 ^{-0.03}	53.3	59	6.3	3.5	6.2
16	178	111	60	10.6 ^{-0.03}	53.3	70	6.3	4.3	8
25	203	115	62	10 ^{±0.05}	69.5	100	6.3	4.5	10

Size	D9 ∅	H1	H2 ±0.2	H3	H4	H5 ±0.2	H6	H7	H9	H10
12	13	120	34	278	40	40	12.5	25	44	312
16	13	160	44	291	20	100	20	40	65	343
25	13	200	75	321	40	100	20	30	101	391

Size	H11	L1 ±0.6	L2 ±0.2	L3	L4	L5	L6	L7	L8 ±1.2
12	344	200	170	7.5	15	85	–	12 ^{-0.01/-0.05}	65
16	397	280	250	7.5	15	75	100	15 ^{-0.01/-0.05}	73
25	485	370	340	7.5	15	30	280	23.2 ^{±0.05}	80

Size	L9 ±3	L10	R1	T3	≈C1	≈C2	≈C3	≈C4	≈C5	Woodruff key to DIN 6885 ¹⁾
12	118	150	200	6	2.5	2	3	2.5	2.5	A2x2x12
16	136	200	306	6.5	3	2.5	3	2.5	2.5	A3x3x18
25	136	250	484	6.3	3	2.5	4	5	3	A4x4x25

1) included in scope of delivery

Handling modules HSP, electric

Technical data

FESTO

Dimensions

Download CAD data → www.festo.com

With motor unit towards the rear

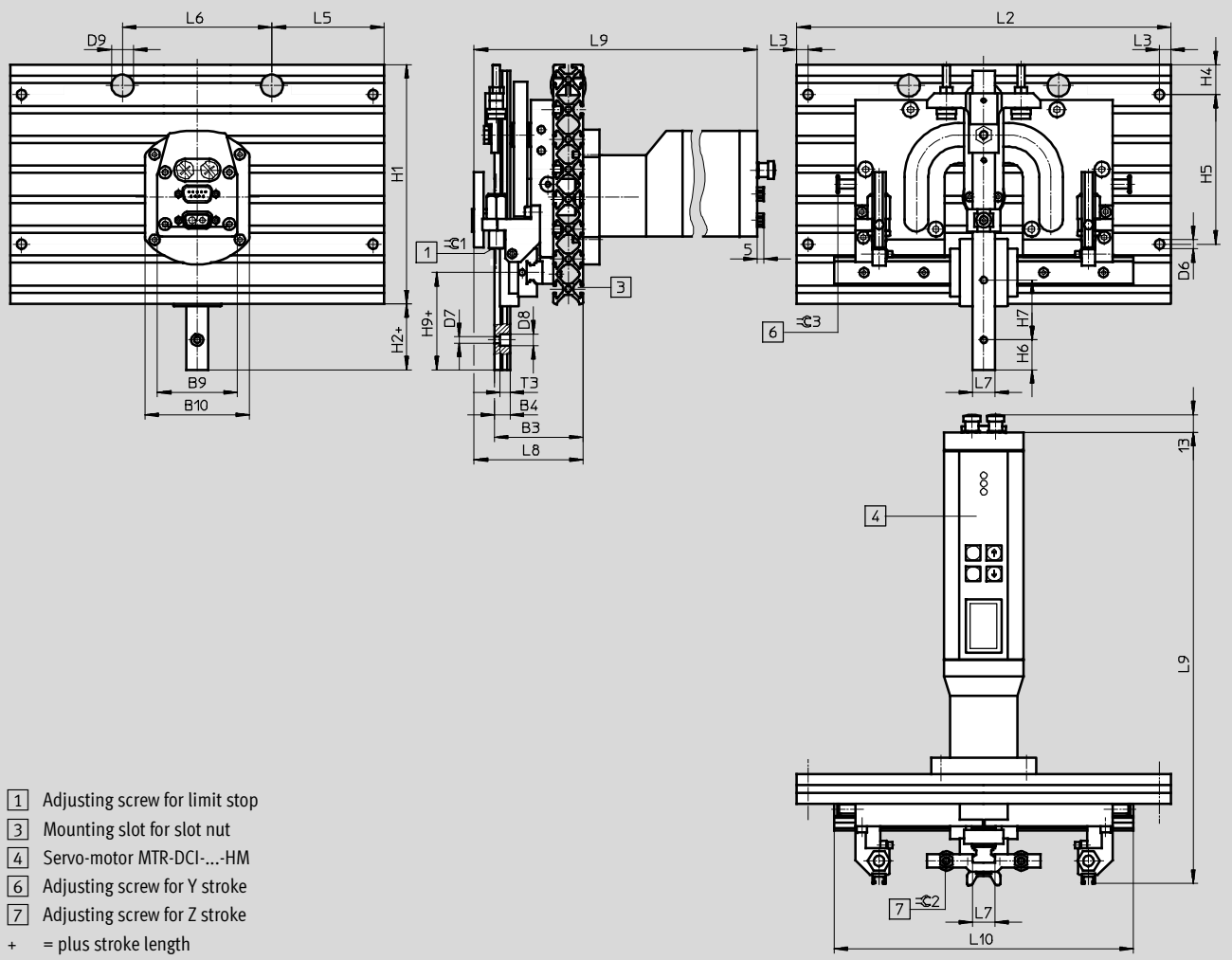

With motor unit towards the rear and protective cover

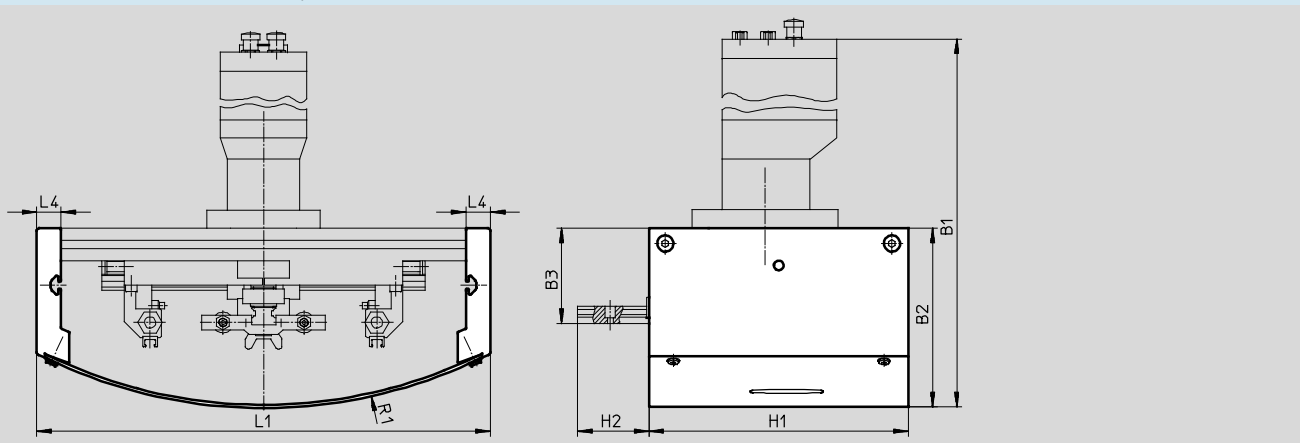

Handling modules HSP, electric

Technical data

Size	B1 ±3	B2 ±2	B3 ±0.5	B4	B9	B10	D6 ∅	D7 ∅
12	308	93	56	9 -0.03	53.3	71	6.3	3.5
16	339	111	60	10.6 -0.03	53.3	70	6.3	4.3
25	372	115	62	10 ±0.05	69.5	90	6.3	4.5

Size	D8 ∅	D9 ∅	H1	H2 ±0.2	H4	H5 ±0.2	H6	H7
12	6.2	13	120	34	40	40	12.5	25
16	8	13	160	44	20	100	20	40
25	10	13	200	75	40	100	20	30

Size	H9	L1 ±0.6	L2 ±0.2	L3	L4	L5	L6	L7
12	44	200	170	7.5	15	85	-	12 -0.01/-0.05
16	65	280	250	7.5	15	75	100	15 -0.01/-0.05
25	101	370	340	7.5	15	30	280	23.2 ±0.05

Size	L8 ±1.2	L9 ±3	L10	R1	T3	≈C1	≈C2	≈C3
12	65	280	150	200	6	6	2	3
16	73	301	200	306	6.5	8	2.5	3
25	80	337	250	484	6.3	8	2.5	4

Ordering data for HSP-...-AE									
Size	12			16			25		
	Part No.	Type		Part No.	Type		Part No.	Type	
I/O connection									
Without gear unit									
Without protective cover	539 536	HSP-12-AE-IO		539 544	HSP-16-AE-IO		539 552	HSP-25-AE-IO	
With protective cover	539 538	HSP-12-AE-IO-SD		539 546	HSP-16-AE-IO-SD		539 554	HSP-25-AE-IO-SD	
With angle gear unit									
Without protective cover	539 537	HSP-12-AE-IO-GE		539 545	HSP-16-AE-IO-GE		539 553	HSP-25-AE-IO-GE	
With protective cover	539 539	HSP-12-AE-IO-SD-GE		539 547	HSP-16-AE-IO-SD-GE		539 555	HSP-25-AE-IO-SD-GE	

Handling modules HSP, without drive

Type codes

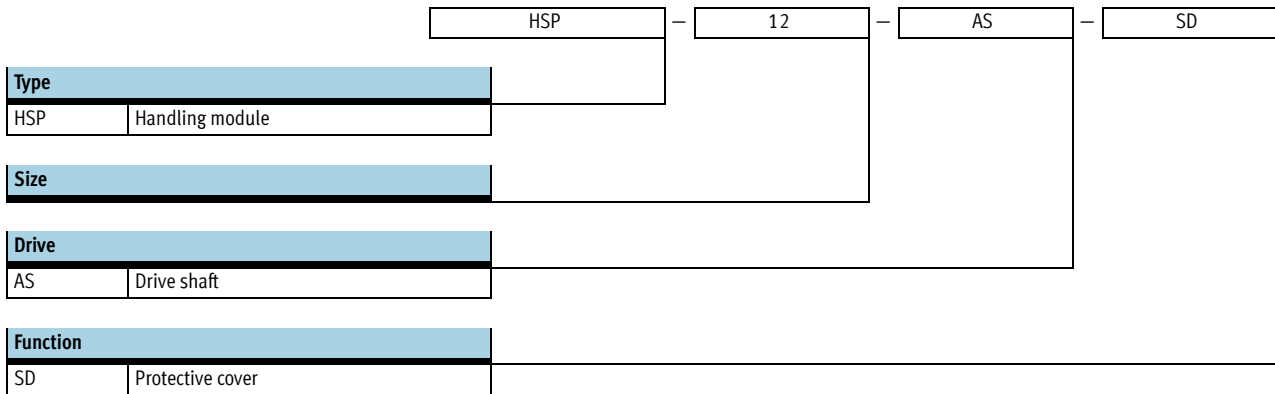

Handling modules HSP, without drive

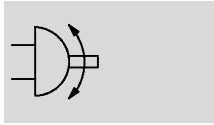

Technical data

Function



 www.festo.com





-  Diameter
12, 16 and 25
-  Y-stroke length
52 ... 170
-  Z-stroke length
20 ... 70

General technical data	
Type	HSP-...-AS
Constructional design	Drive shaft
	Cross-guide
	Guided motion sequence
Cushioning	Noise reduction via buffers
Type of mounting	With through-holes
	With slot nuts
Mounting position	Guide rail, vertical/horizontal

Weight [g]			
Size	12	16	25
HSP-...-AS	1800	2700	6200
HSP-...-AS-SD	2500	3200	7400

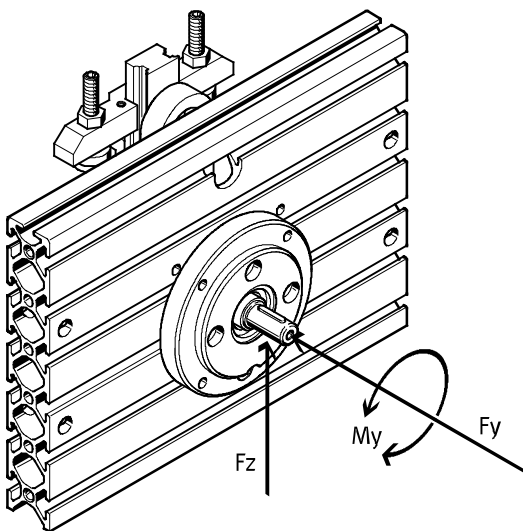
Permissible static/dynamic characteristic load values



 Note
Technical data for mechanical components → 21.

Characteristic load values			
Size	12	16	25
Max. axial force $F_{Yperm.}$	[N] 18	30	50
Max. radial force $F_{Zperm.}$	[N] 45	75	120
Max. drive torque $M_{Yperm.}$	[Nm] 1.25	2.5	5

Handling modules HSP, without drive

Technical data

Mass moment of inertia J_0 as a function of working load m (for cylinder sizing)

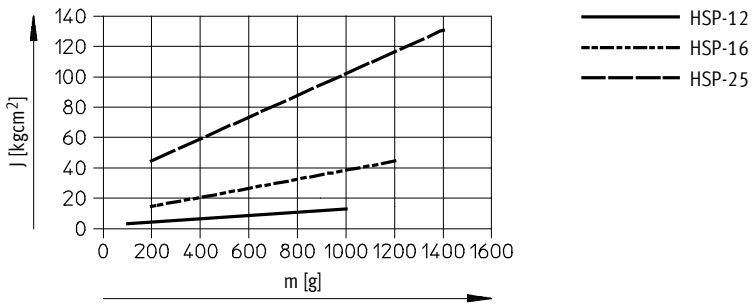

Dimensions

Download CAD data → www.festo.com

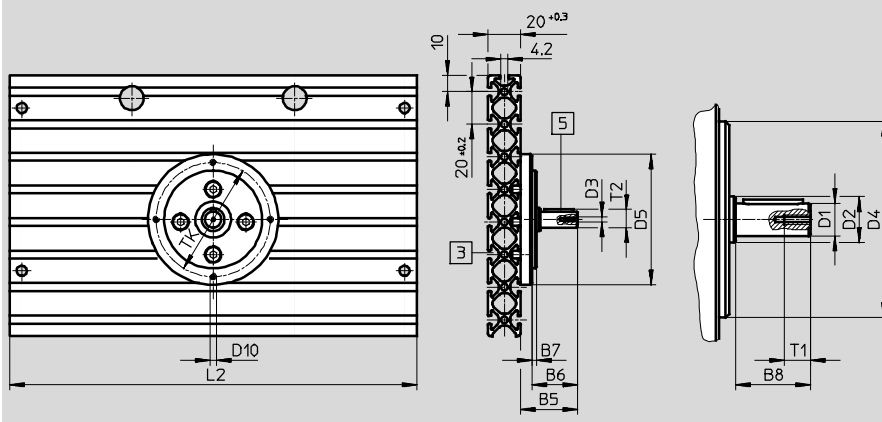

- Basic dimensions
→ 28
- 3 Mounting slot for slot nut
 - 5 Woodruff key

Size	B5	B6	B7	B8	D1 ∅ g7	D2 ∅	D3
12	29	22	3	17.5	8	12.5	M3
16	35	28	3	23	10	14	M3
25	44	36	4	30	12	17	M4

Size	D4 ∅ f8	D5 ∅	D10	L2 ±0.2	T1	T2 max.	TK ±0.1
12	45	65	M4	170	9	8.8	55
16	60	80	M4	250	9	11.2	70
25	70	95	M5	340	10	13.5	82

Handling modules HSP, without drive

Technical data

Ordering data for HSP-...-AS						
Size	12		16		25	
	Part No.	Type	Part No.	Type	Part No.	Type
Without protective cover	533 605	HSP-12-AS	533 613	HSP-16-AS	533 621	HSP-25-AS
With protective cover	533 606	HSP-12-AS-SD	533 614	HSP-16-AS-SD	533 622	HSP-25-AS-SD

Handling modules HSP

Accessories



Adapter kit HAPG-B

Material:
Wrought aluminium alloy, anodised

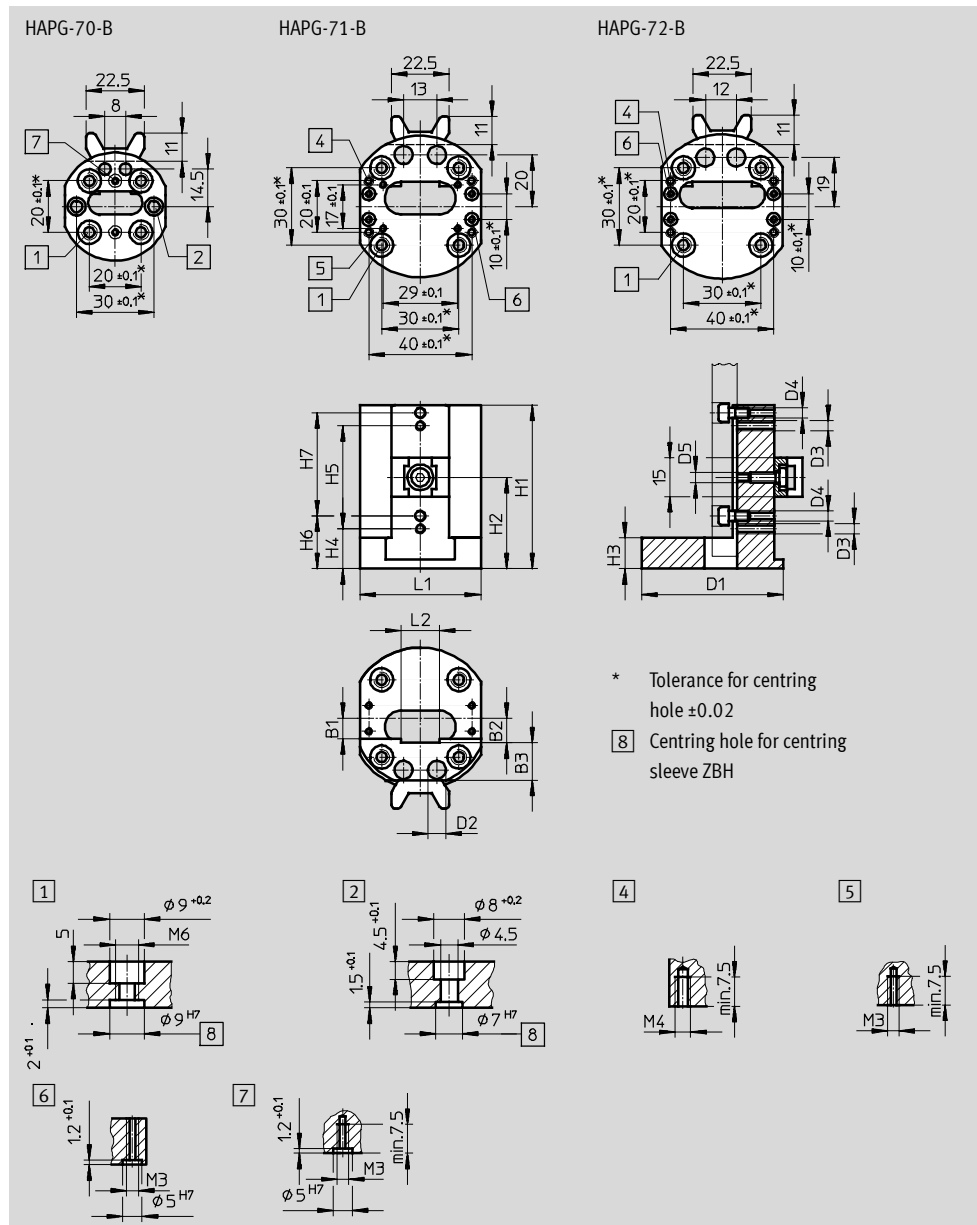

Dimensions and ordering data										
Type	B1	B2	B3	D1	D2	D3	D4	D5	H1	H2
HAPG-70-B	5	6	11.5	$\varnothing 42$	4.5	-	M3	M4	50	28.5
HAPG-71-B	8	9.5	14.5	56	7	M4	M4	M4	63.5	35.5
HAPG-72-B	8	9.5	15	56	7	-	M4	M4	60	41.5

Type	H3	H4	H5	H6	H7	L1	L2	Weight	Part No.	Type
HAPG-70-B	12	-	-	15	25	39	12	55	540 881	HAPG-70-B
HAPG-71-B	12	15.5	40	20.5	40	47	15	110	540 882	HAPG-71-B
HAPG-72-B	12	-	-	20.5	30	47	23.2	115	540 883	HAPG-72-B

Handling modules HSP

Accessories

Installation kit MKRP

Material:
 Conduit/fitting: Polyamide
 Reducer/lock nut:
 Nickel-plated brass
 Adapter plate/bracket:
 Powder-coated steel

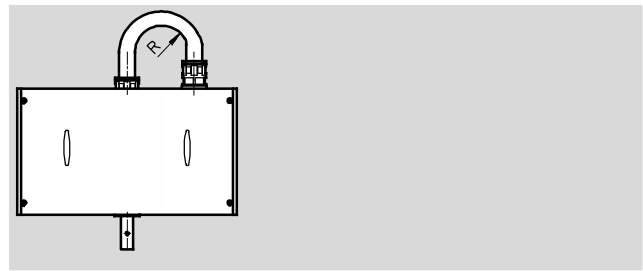

Ordering data					
For size	Max. bending radius for conduit ¹⁾	Tubing I.D.	Weight	Part No.	Type
	R	[mm]	[g]		
12	55	12	150	533 632	MKRP-1
16	75	16.5	160	533 633	MKRP-2
25	75	16.5	160	533 634	MKRP-3

1) The conduit must not be filled beyond 70%.

Cover kit BSD-HSP

Material:
 Wrought aluminium alloy, anodised



Dimensions HSP-...-AP → 16
 HSP-...-AE → 30
 HSP-...-AS → 30

Ordering data			
For size	Weight	Part No.	Type
	[g]		
12	825	533 635	BSD-HSP-12
16	1 350	533 636	BSD-HSP-16
25	1 770	533 637	BSD-HSP-25

Wait position module BWL-/BWR-HSP for HSP-...-AP

Material:
 Wrought aluminium alloy, anodised



Dimensions → 16

Ordering data				
For size	Wait position	Weight	Part No.	Type
		[g]		
12	Right	75	533 623	BWR-HSP-12
	Left	75	533 624	BWL-HSP-12
16	Right	135	533 625	BWR-HSP-16
	Left	135	533 626	BWL-HSP-16
25	Right	275	533 627	BWR-HSP-25
	Left	275	533 628	BWL-HSP-25



Handling modules HSP

Accessories

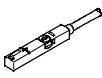
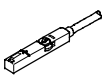
FESTO

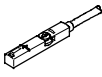
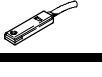
Ordering data – Proximity sensors for T-slot, magneto-resistive						Technical data → Internet: smt
	Type of mounting	Switch output	Electrical connection	Cable length [m]	Part No.	Type
N/O contact						
	Insertable in the slot from above, flush with cylinder profile, short design	PNP	Cable, 3-wire	2.5	574335	SMT-8M-A-PS-24V-E-2,5-OE
			Plug M8x1, 3-pin	0.3	574334	SMT-8M-A-PS-24V-E-0,3-M8D
			Plug M12x1, 3-pin	0.3	574337	SMT-8M-A-PS-24V-E-0,3-M12
		NPN	Cable, 3-wire	2.5	574338	SMT-8M-A-NS-24V-E-2,5-OE
			Plug M8x1, 3-pin	0.3	574339	SMT-8M-A-NS-24V-E-0,3-M8D
N/C contact						
	Insertable in the slot from above, flush with cylinder profile, short design	PNP	Cable, 3-wire	7.5	574340	SMT-8M-A-PO-24V-E-7,5-OE



Ordering data – Proximity sensors for T-slot, magnetic reed						Technical data → Internet: sme	
	Type of mounting	Switch output	Electrical connection	Cable length [m]	Part No.	Type	
N/O contact							
	Insertable in the slot from above, flush with cylinder profile	Contacting	Cable, 3-wire	2.5	543 862	SME-8M-DS-24V-K-2,5-OE	
				5.0	543 863	SME-8M-DS-24V-K-5,0-OE	
			Cable, 2-wire	2.5	543 872	SME-8M-ZS-24V-K-2,5-OE	
				Plug M8x1, 3-pin	0.3	543 861	SME-8M-DS-24V-K-0,3-M8D
				Contacting	Cable, 3-wire	2.5	150 855
Plug M8x1, 3-pin	0.3	150 857	SME-8-S-LED-24				
N/C contact							
	Insertable in the slot lengthwise, flush with the cylinder profile	Contacting	Cable, 3-wire	7.5	160 251	SME-8-O-K-LED-24	



Ordering data – Connecting cables					Technical data → Internet: nebu
	Electrical connection, left	Electrical connection, right	Cable length [m]	Part No.	Type
	Straight socket, M8x1, 3-pin	Cable, open end, 3-wire	2.5	541 333	NEBU-M8G3-K-2.5-LE3
			5	541 334	NEBU-M8G3-K-5-LE3
	Straight socket, M12x1, 5-pin	Cable, open end, 3-wire	2.5	541 363	NEBU-M12G5-K-2.5-LE3
			5	541 364	NEBU-M12G5-K-5-LE3
	Angled socket, M8x1, 3-pin	Cable, open end, 3-wire	2.5	541 338	NEBU-M8W3-K-2.5-LE3
			5	541 341	NEBU-M8W3-K-5-LE3
	Angled socket, M12x1, 5-pin	Cable, open end, 3-wire	2.5	541 367	NEBU-M12W5-K-2.5-LE3
			5	541 370	NEBU-M12W5-K-5-LE3

Handling modules HSP

Accessories

FESTO

Ordering data		Technical data → Internet: abp, hmbn	
	Brief description	Part No.	Type
Slot cover for T-slot			
	For protecting against ingress of dirt and securing proximity sensor cables. Scope of delivery: 2x 0.5 m	151 680	ABP-5-S
Slot nut for back plate			
	Inserted from above	189 654	HMBN-5-M5

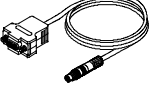
Ordering data – Cables for HSP-AE				
	Brief description	Cable length	Part No.	Type
	Supply cable	2.5 m	537 931	KPWR-MC-1-SUB-9HC-2,5
		5 m	537 932	KPWR-MC-1-SUB-9HC-5
		10 m	537 933	KPWR-MC-1-SUB-9HC-10
	Control cable for I/O connection to any PLC controller	2.5 m	537 923	KES-MC-1-SUB-9-2,5
		5 m	537 924	KES-MC-1-SUB-9-5
		10 m	537 925	KES-MC-1-SUB-9-10
	Programming cable	2.5 m	537 926	KDI-MC-M8-SUB-9-2,5

Ordering data – Software for HSP-AE			
	Brief description	Part No.	Type
	The operator's package: – CD-ROM – With user's manual in the languages DE, EN, ES, FR, IT, SV – With configuration package FCT (Festo Configuration Tool) – Brief description The operator's package is included in the delivery.	541 951	P.BP-HSP_HSW-AE

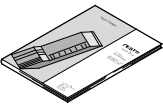
Ordering data – Documentation for HSP-AE				
	Brief description	Language	Part No.	Type
	Description User's manual in paper form is not included in the scope of delivery.	DE	541 945	P.BE-HSP-AE-IO-DE
		EN	541 946	P.BE-HSP-AE-IO-EN
		ES	541 947	P.BE-HSP-AE-IO-ES
		FR	541 948	P.BE-HSP-AE-IO-FR
		IT	541 949	P.BE-HSP-AE-IO-IT
		SV	541 950	P.BE-HSP-AE-IO-SV